

Inverter MICROMASTER 440



4/2	Description
4/4	Circuit diagrams
4/6	Technical data
4/9	Selection and ordering data
4/12	Options
4/26	Dimension drawings

MICROMASTER 440

Description



Application

The MICROMASTER 440 inverter is suitable for a variety of variable-speed drive applications. Its flexibility provides for a wide spectrum of applications. These also include cranes and hoisting gear, high-bay warehouses, production machines for food, beverages and tobacco, packaging machines etc.; i.e. applications which require the frequency inverter to have a higher functionality and dynamic response than usual.

The inverter is especially characterized by its customer-oriented performance and ease-of-use. Its large mains voltage range enables it to be used all over the world.

Design

The MICROMASTER 440 inverter has a modular design. The operator panels and modules can be easily exchanged.

International standards

- The MICROMASTER 440 inverter complies with the requirements of the EU low-voltage guideline
- The MICROMASTER 440 inverter has the **CE** marking
- acc. to **®** and **c®** certified
- c-tick **C**

Note:

- See Appendix for standards.

Main characteristics

- Easy, guided start-up
- Modular construction allows maximum configuration flexibility
- Six programmable isolated digital inputs
- Two scaleable analog inputs (0 V to 10 V, 0 mA to 20 mA) can also be used as a 7th/8th digital input
- Two programmable analog outputs (0 mA to 20 mA)
- Three programmable relay outputs (30 V DC/5 A resistive load; 250 V AC/2A inductive load)
- Low-noise motor operation thanks to high pulse frequencies, adjustable (observe derating if necessary)
- Complete protection for motor and inverter.

Options (overview)

- EMC filter, Class A/B
- LC filter and sinusoidal filter
- Line commutating chokes
- Output chokes
- Gland plates

- Basic Operator Panel (BOP) for parameterizing the inverter
- Plain text Advanced Operator Panel (AOP) with multi-language display
- Plain text Asian Advanced Operator Panel (AAOP) with Chinese and English display
- Plain text Cyrillic Advanced Operator Panel (CAOP) with Cyrillic, German and English display
- Communication modules
 - PROFIBUS
 - DeviceNet
 - CANopen
- Pulse encoder evaluation module
- PC connection kits
- Mounting kits for installing the operator panels in the control cabinet doors
- PC start-up tools executable under Windows 98 and NT/2000/ME/XP Professional
- TIA integration with Drive ES.

Mechanical features

- Modular design
- Operating temperature
0.12 kW to 75 kW:
-10 °C to +50 °C
(+14 °F to +122 °F)
90 kW to 200 kW:
0 °C to +40 °C
(+32 °F to +104 °F)
- Compact housing as a result of high power density
- Easy cable connection, mains and motor connections are separated for optimum electromagnetic compatibility
- Detachable operator panels
- Screwless control terminals on detachable I/O board.

Performance features

- Latest IGBT technology
- Digital microprocessor control
- High-quality Vector Control system
- Flux Current Control (FCC) for improved dynamic response and optimized motor control
- Linear V/f characteristic
- Quadratic V/f characteristic
- Multipoint characteristic (programmable V/f characteristic)
- Torque control
- Flying restart
- Slip compensation
- Automatic restart following mains failure or fault
- User-definable function blocks for logic and arithmetic operations
- Kinetic buffering
- Positioning ramp down
- High-grade PID controller for simple internal process control (autotuning)
- Programmable acceleration/deceleration, 0 s to 650 s
- Ramp smoothing
- Fast Current Limit (FCL) for trip-free operation
- Fast, repeatable digital input response time
- Fine adjustment using two high-resolution 10-bit analog inputs
- Compound braking for controlled rapid braking
- Integrated brake chopper (for 0.12 kW to 75 kW inverters)
- Four skip frequencies
- Removable "Y" capacitor for use on IT systems (with non-grounded mains supplies, the "Y" capacitor must be removed and an output choke installed).

Protection features

- Overload capability
 - **CT mode**
0.12 kW to 75 kW:
Overload current 1.5 x rated output current (i.e. 150 % overload capability) for 60 s, cycle time 300 s, and 2 x rated output current (i.e. 200 % overload capability) for 3 s, cycle time 300 s
 - 90 kW to 200 kW:
Overload current 1.36 x rated output current (i.e. 136 % overload capability) for 57 s, cycle time 300 s, and 1.6 x rated output current (i.e. 160 % overload capability) for 3 s, cycle time 300 s
 - **VT mode**
5.5 kW to 90 kW:
Overload current 1.4 x rated output current (i.e. 140 % overload capability) for 3 s, and 1.1 x rated output current (i.e. 110 % overload capability) for 60 s, cycle time 300 s
 - 110 kW to 250 kW:
Overload current 1.5 x rated output current (i.e. 150 % overload capability) for 1 s, and 1.1 x rated output current (i.e. 110 % overload capability) for 59 s, cycle time 300 s
- Overvoltage/undervoltage protection
- Inverter overtemperature protection
- Special direct connection for PTC or KTY to protect the motor
- Earth fault protection
- Short-circuit protection
- βt motor thermal protection
- Locked motor protection
- Stall prevention
- Parameter interlock.

MICROMASTER 440

Circuit diagrams

General circuit diagram

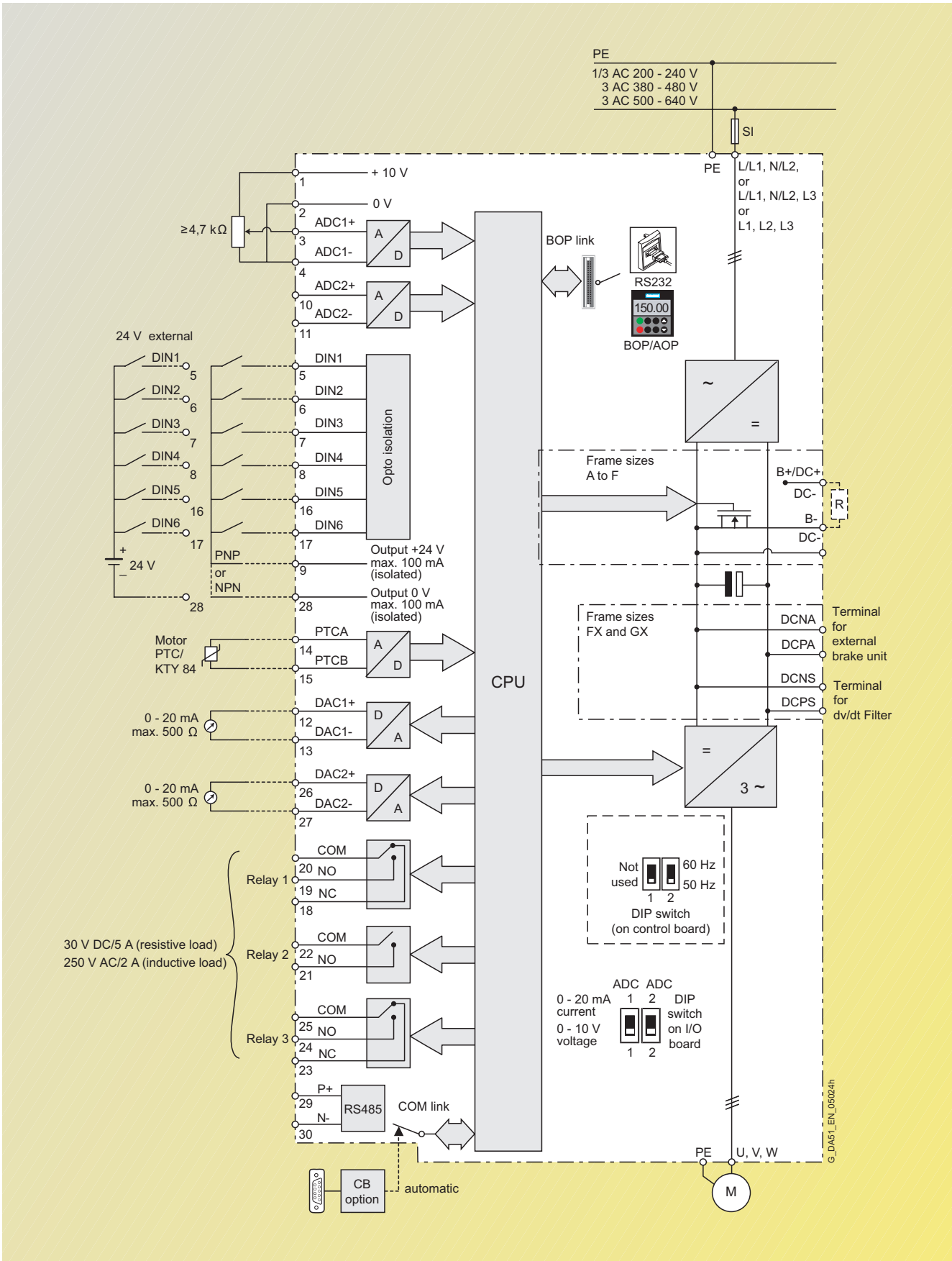

4

Terminal connection diagram

Example, frame size FX

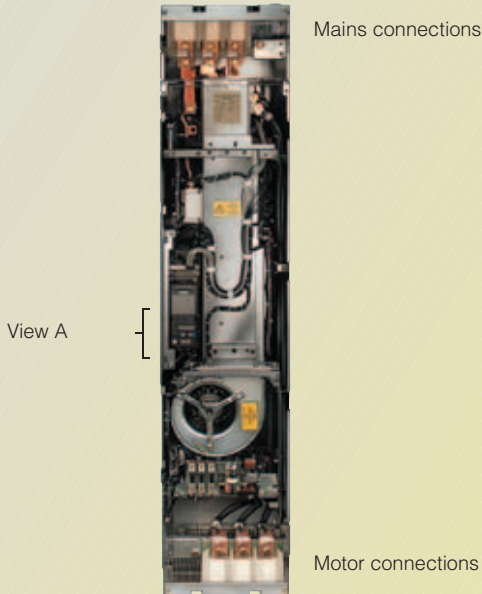

View A

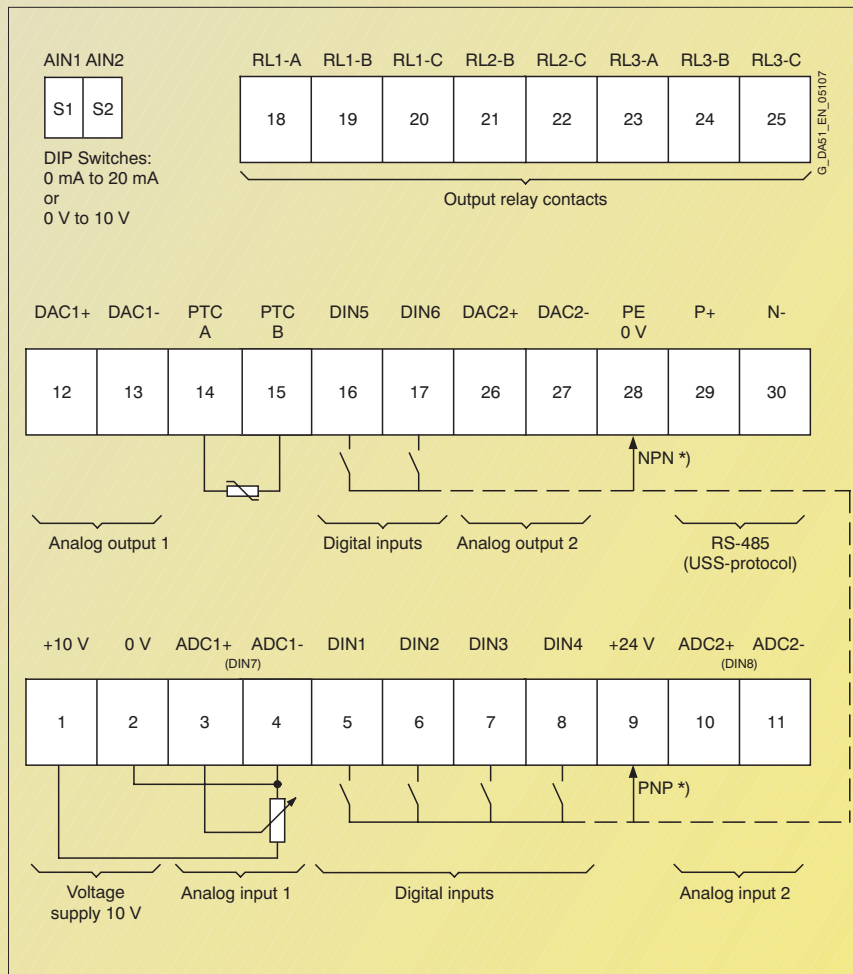

*) PNP or NPN possible

MICROMASTER 440

Technical data

MICROMASTER 440 inverter

Mains voltage and power ranges		1 AC 200 V to 240 V ± 10 % 3 AC 200 V to 240 V ± 10 % 3 AC 380 V to 480 V ± 10 % 3 AC 500 V to 600 V ± 10 %	CT (constant torque) 0.12 kW to 3 kW 0.12 kW to 45 kW 0.37 kW to 200 kW 0.75 kW to 75 kW	VT (variable torque) – 5.5 kW to 55 kW 7.5 kW to 250 kW 1.5 kW to 90 kW
Input frequency		47 Hz to 63 Hz		
Output frequency	0.12 kW to 75 kW 90 kW to 200 kW	0 Hz to 650 Hz (in V/f mode) 0 Hz to 267 Hz (in V/f mode)	0 Hz to 200 Hz (in vector mode) 0 Hz to 200 Hz (in vector mode)	
Power factor		≥ 0.95		
Inverter efficiency		0.12 kW to 75 kW: 96 % to 97 %; 90 kW to 200 kW: 97 % to 98 % (Further information is available on the Internet at: http://support.automation.siemens.com/WW/view/en/22978972)		
Overload capability		Overload current 1.5 x rated output current (i.e. 150 % overload capability) for 60 s, cycle time 300 s and 2 x rated output current (i.e. 200 % overload capability) for 3 s, cycle time 300 s		
– CT mode	0.12 kW to 75 kW 90 kW to 200 kW	Overload current 1.36 x rated output current (i.e. 136 % overload capability) for 57 s, cycle time 300 s and 1.6 x rated output current (i.e. 160 % overload capability) for 3 s, cycle time 300 s		
– VT mode	5.5 kW to 90 kW 110 kW to 250 kW	Overload current 1.4 x rated output current (i.e. 140 % overload capability) for 3 s, and 1.1 x rated output current (i.e. 110 % overload capability) for 60 s, cycle time 300 s Overload current 1.5 x rated output current (i.e. 150 % overload capability) for 1 s, and 1.1 x rated output current (i.e. 110 % overload capability) for 59 s, cycle time 300 s		
Inrush current		not higher than rated input current		
Control method		Vector control, torque control, linear V/f characteristic; quadratic V/f characteristic; Multipoint characteristic (programmable V/f characteristic); flux current control (FCC)		
Pulse frequency	0.12 kW to 75 kW 90 kW to 200 kW	4 kHz (standard); 16 kHz (standard with 230 V inverters 0.12 kW to 5.5 kW) 2 kHz to 16 kHz (in 2 kHz steps) 2 kHz (standard with VT mode); 4 kHz (standard with CT mode) 2 kHz to 4 kHz (in 2 kHz steps)		
Fixed frequencies		15, programmable		
Skip frequency ranges		4, programmable		
Setpoint resolution		0.01 Hz digital; 0.01 Hz serial; 10 bit analog		
Digital inputs		6 fully programmable isolated digital inputs; switchable PNP/NPN		
Analog inputs		2 programmable analog inputs • 0 V to 10 V, 0 mA to 20 mA and –10 V to +10 V (AIN1) • 0 V to 10 V and 0 mA to 20 mA (AIN2) • both can be used as 7th/8th digital input		
Relay outputs		3, programmable, 30 V DC/5 A (resistive load); 250 V AC/2A (inductive load)		
Analog outputs		2, programmable (0/4 mA to 20 mA)		
Serial interfaces		RS-485, optional RS-232		
Motor cable lengths	without output choke with output choke	0.12 – 75 kW: max. 50 m (shielded), max. 100 m (unshielded) 90 – 250 kW: max. 200 m (shielded), max. 300 m (unshielded) see variant dependent options		
Electromagnetic compatibility (see Selection and Ordering Data)		EMC filter, Class A or Class B to EN 55 011 available as an option Inverter with internal filter Class A available		
Braking		Resistance braking with DC braking, compound braking, integrated brake chopper (integrated brake chopper only with 0.12 kW to 75 kW inverters)		
Degree of protection		IP20		
Operating temperature (without derating)	0.12 kW to 75 kW 90 kW to 200 kW	CT: –10 °C to +50 °C (+14 °F to +122 °F) VT: –10 °C to +40 °C (+14 °F to +104 °F) 0 °C to +40 °C (+32 °F to +104 °F)		
Storage temperature		–40 °C to +70 °C (–40 °F to +158 °F)		
Relative humidity		95% (non-condensing)		
Installation altitude	0.12 kW to 75 kW 90 kW to 200 kW	up to 1000 m above sea level without derating up to 2000 m above sea level without derating		
Standard SCCR (Short Circuit Current Rating) ¹⁾		FSA, FSB, FSC: 10 kA FSD, FSE, FSF, FSFX, FSGX: 42 kA		
Protection features for		Undervoltage, overvoltage, overload, earth faults, short-circuits, stall prevention, locked motor protection, motor over-temperature, inverter overtemperature, parameter change protection		
Compliance with standards		Ⓢ, cⓈ, CE, c-tick		
CE marking		Conformity with low-voltage directive 73/23/EEC		
Cooling-air volumetric flow required, dimensions and weights (without options)		Frame size (FS)	Cooling-air volumetric flow required (l/s)/(CFM)	H x W x D, max. (mm) Weight, approx. (kg)
		A	4.8/10.2	173 x 73 x 149 1.3
		B	24/51	202 x 149 x 172 3.4
		C	54.9/116.3	245 x 185 x 195 5.7
		D	2 x 54.9/2 x 116.3	520 x 275 x 245 17
		E	2 x 54.9/2 x 116.3	650 x 275 x 245 22
		F without filter	150/317.79	850 x 350 x 320 56
		F with filter	150/317.79	1150 x 350 x 320 75
		FX	225/478.13	1400 x 326 x 356 116
		GX	440/935	1533 x 326 x 545 174

1) For footnote, see page 4/7.

CFM: Cubic Feet per Minute

Derating data

Pulse frequency

Output kW	Rated output current in A for a pulse frequency of						
	4 kHz	6 kHz	8 kHz	10 kHz	12 kHz	14 kHz	16 kHz
Mains voltage 1/3 AC 200 V							
0.12 to 5.5	Values correspond to the 4 kHz standard values. No derating, since 16 kHz standard.						
7.5	28.0	26.6	25.2	22.4	19.6	16.8	14.0
11	42.0	37.8	33.6	29.4	25.2	21.0	16.8
15	54.0	48.6	43.2	37.8	32.4	27.0	21.6
18.5	68.0	64.6	61.2	54.4	47.6	40.8	34.0
22	80.0	72.0	64.0	56.0	48.0	40.0	32.0
30	104.0	91.0	78.0	70.2	62.4	57.2	52.0
37	130.0	113.8	97.5	87.8	78.0	71.5	65.0
45	154.0	134.8	115.5	104.0	92.4	84.7	77.0
Mains operating voltage 3 AC 400 V							
0.37	1.3	1.3	1.3	1.3	1.3	1.2	1.0
0.55	1.7	1.7	1.7	1.6	1.5	1.4	1.2
0.75	2.2	2.2	2.2	2.0	1.8	1.5	1.3
1.1	3.1	2.9	2.8	2.5	2.2	1.9	1.6
1.5	4.1	3.7	3.3	2.9	2.5	2.1	1.6
2.2	5.9	5.6	5.3	4.7	4.1	3.5	3.0
3.0	7.7	6.9	6.2	5.4	4.6	3.9	3.1
4.0	10.2	9.2	8.2	7.1	6.1	5.1	4.1
5.5	13.2	11.9	10.6	9.2	7.9	6.6	5.3
7.5	19.0	18.1	17.1	15.2	13.3	11.4	9.5
11.0	26.0	23.4	20.8	18.2	15.6	13.0	10.4
15.0	32.0	30.4	28.8	25.6	22.4	19.2	16.0
18.5	38.0	34.2	30.4	26.6	22.8	19.0	15.2
22	45.0	40.5	36.0	31.5	27.0	22.5	18.0
30	62.0	58.9	55.8	49.6	43.4	37.2	31.0
37	75.0	67.5	60.0	52.5	45.0	37.5	30.0
45	90.0	76.5	63.0	51.8	40.5	33.8	27.0
55	110.0	93.5	77.0	63.3	49.5	41.3	33.0
75	145.0	112.4	79.8	68.9	58.0	50.8	43.5
90	178.0	–	–	–	–	–	–
110	205.0	–	–	–	–	–	–
132	250.0	–	–	–	–	–	–
160	302.0	–	–	–	–	–	–
200	370.0	–	–	–	–	–	–
Mains operating voltage 3 AC 500 V							
0.75	1.4	1.2	1.0	0.8	0.7	0.6	0.6
1.5	2.7	2.2	1.6	1.4	1.1	0.9	0.8
2.2	3.9	2.9	2.0	1.6	1.2	1.0	0.8
4.0	6.1	4.6	3.1	2.4	1.8	1.5	1.2
5.5	9.0	6.8	4.5	3.6	2.7	2.3	1.8
7.5	11.0	8.8	6.6	5.5	4.4	3.9	3.3
11.0	17.0	12.8	8.5	6.8	5.1	4.3	3.4
15.0	22.0	17.6	13.2	11.0	8.8	7.7	6.6
18.5	27.0	20.3	13.5	10.8	8.1	6.8	5.4
22	32.0	24.0	16.0	12.8	9.6	8.0	6.4
30	41.0	32.8	24.6	20.5	16.4	14.4	12.3
37	52.0	39.0	26.0	20.8	15.6	13.0	10.4
45	62.0	52.7	43.4	40.3	37.2	32.6	27.9
55	77.0	67.4	57.8	52.0	46.2	42.4	38.5
75	99.0	84.2	69.3	64.4	59.4	52.0	44.6

1) Applies to industrial control cabinet installations to NEC article 409/UL 508A.

For further information, visit us on the Internet at:

<http://support.automation.siemens.com/WW/view/en/23995621>

MICROMASTER 440

Technical data

Derating data (continued)

Operating temperature

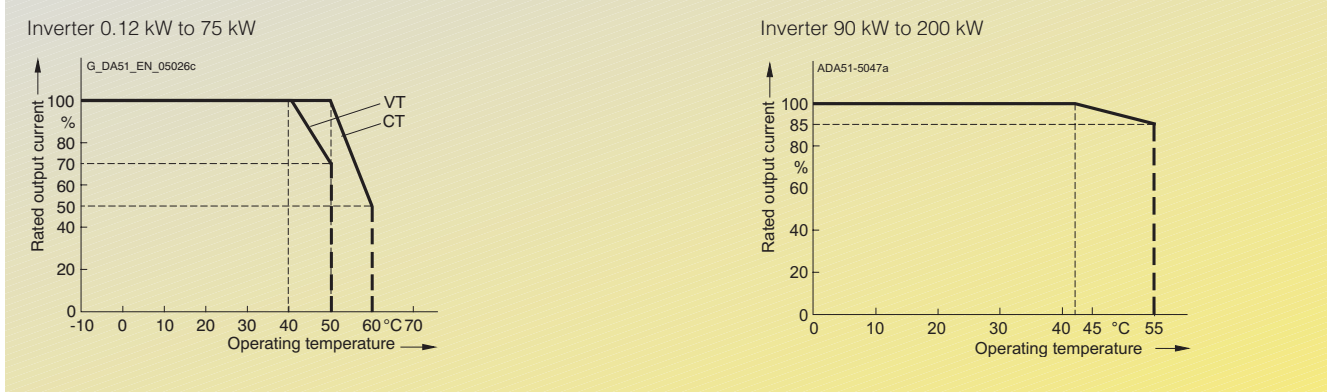

Installation altitude above sea level

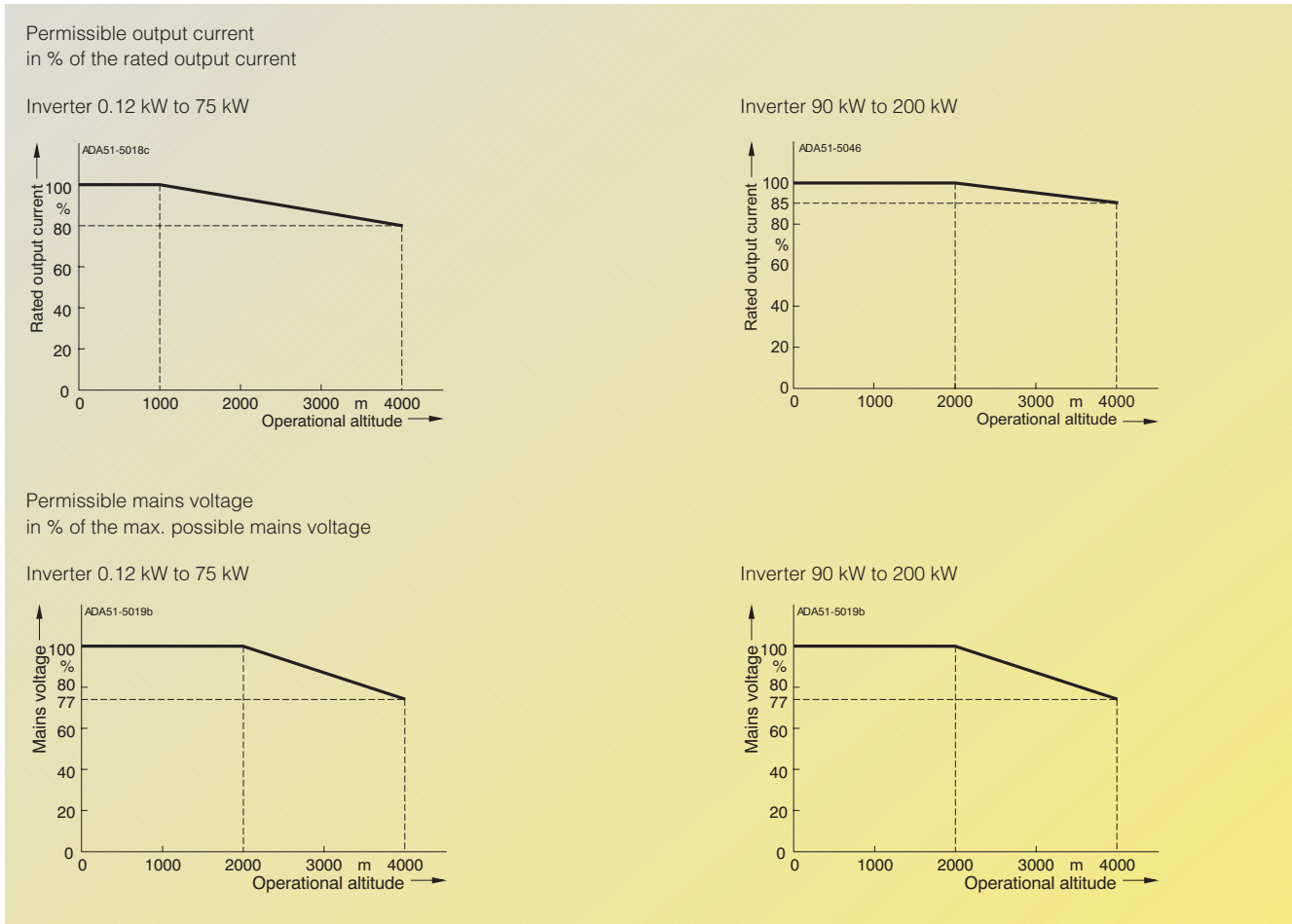

4

MICROMASTER 440 inverter without filter²⁾

CT (constant torque)				VT (variable torque)				MICROMASTER 440 without filter ²⁾		
Output		Rated input current ¹⁾	Rated output current	Output		Rated input current ¹⁾	Rated output current	Frame size (FS)	Weight, approx. kg	Order No.
kW	hp	A	A	kW	hp	A	A			
Mains voltage 1 AC 200 V to 240 V										
0.12	0.16	1.8	0.9	–	–	–	–	A	1.3	6SE6440-2UC11-2AA1
0.25	0.33	3.2	1.7	–	–	–	–	A	1.3	6SE6440-2UC12-5AA1
0.37	0.50	4.6	2.3	–	–	–	–	A	1.3	6SE6440-2UC13-7AA1
0.55	0.75	6.2	3.0	–	–	–	–	A	1.3	6SE6440-2UC15-5AA1
0.75	1.0	8.2	3.9	–	–	–	–	A	1.3	6SE6440-2UC17-5AA1
1.1	1.5	11.0	5.5	–	–	–	–	B	3.3	6SE6440-2UC21-1BA1
1.5	2	14.4	7.4	–	–	–	–	B	3.3	6SE6440-2UC21-5BA1
2.2	3	20.2	10.4	–	–	–	–	B	3.3	6SE6440-2UC22-2BA1
3.0	4	35.5	13.6	–	–	–	–	C	5.5	6SE6440-2UC23-0CA1
Mains operating voltage 3 AC 200 V to 240 V										
0.12	0.16	1.1	0.9	–	–	–	–	A	1.3	6SE6440-2UC11-2AA1
0.25	0.33	1.9	1.7	–	–	–	–	A	1.3	6SE6440-2UC12-5AA1
0.37	0.50	2.7	2.3	–	–	–	–	A	1.3	6SE6440-2UC13-7AA1
0.55	0.75	3.6	3.0	–	–	–	–	A	1.3	6SE6440-2UC15-5AA1
0.75	1.0	4.7	3.9	–	–	–	–	A	1.3	6SE6440-2UC17-5AA1
1.1	1.5	6.4	5.5	–	–	–	–	B	3.3	6SE6440-2UC21-1BA1
1.5	2.0	8.3	7.4	–	–	–	–	B	3.3	6SE6440-2UC21-5BA1
2.2	3.0	11.7	10.4	–	–	–	–	B	3.3	6SE6440-2UC22-2BA1
3.0	4.0	15.6	13.6	–	–	–	–	C	5.5	6SE6440-2UC23-0CA1
4.0	5.0	19.7	17.5	5.5	7.5	28.3	22	C	5.5	6SE6440-2UC24-0CA1
5.5	7.5	26.5	22	7.5	10	34.2	28	C	5.5	6SE6440-2UC25-5CA1
7.5	10	34.2	28	11.0	15	38.0	42	D	16	6SE6440-2UC27-5DA1
11.0	15	38.0	42	15.0	20	50.0	54	D	16	6SE6440-2UC31-1DA1
15.0	20	50.0	54	18.5	25	62.0	68	D	16	6SE6440-2UC31-5DA1
18.5	25	62.0	68	22	30	71.0	80	E	20	6SE6440-2UC31-8EA1
22	30	71.0	80	30	40	96.0	104	E	20	6SE6440-2UC32-2EA1
30	40	96.0	104	37	50	114.0	130	F	55	6SE6440-2UC33-0FA1
37	50	114.0	130	45	60	135.0	154	F	55	6SE6440-2UC33-7FA1
45	60	135.0	154	55	75	164.0	178	F	55	6SE6440-2UC34-5FA1
Mains operating voltage 3 AC 380 V to 480 V										
0.37	0.50	2.2	1.3	–	–	–	–	A	1.3	6SE6440-2UD13-7AA1
0.55	0.75	2.8	1.7	–	–	–	–	A	1.3	6SE6440-2UD15-5AA1
0.75	1.0	3.7	2.2	–	–	–	–	A	1.3	6SE6440-2UD17-5AA1
1.1	1.5	4.9	3.1	–	–	–	–	A	1.3	6SE6440-2UD21-1AA1
1.5	2.0	5.9	4.1	–	–	–	–	A	1.3	6SE6440-2UD21-5AA1
2.2	3.0	7.5	5.9	–	–	–	–	B	3.3	6SE6440-2UD22-2BA1
3.0	4.0	10.0	7.7	–	–	–	–	B	3.3	6SE6440-2UD23-0BA1
4.0	5.0	12.8	10.2	–	–	–	–	B	3.3	6SE6440-2UD24-0BA1
5.5	7.5	15.6	13.2	7.5	10	17.3	19	C	5.5	6SE6440-2UD25-5CA1
7.5	10	22.0	18.4	11.0	15	23.1	26	C	5.5	6SE6440-2UD27-5CA1
11.0	15	23.1	26	15.0	20	33.8	32	C	5.5	6SE6440-2UD31-1CA1
15.0	20	33.8	32	18.5	25	37.0	38	D	16	6SE6440-2UD31-5DA1
18.5	25	37.0	38	22	30	43.0	45	D	16	6SE6440-2UD31-8DA1
22	30	43.0	45	30	40	59.0	62	D	16	6SE6440-2UD32-2DA1
30	40	59.0	62	37	50	72.0	75	E	20	6SE6440-2UD33-0EA1
37	50	72.0	75	45	60	87.0	90	E	20	6SE6440-2UD33-7EA1
45	60	87.0	90	55	75	104.0	110	F	56	6SE6440-2UD34-5FA1
55	75	104.0	110	75	100	139.0	145	F	56	6SE6440-2UD35-5FA1
75	100	139.0	145	90	125	169.0	178	F	56	6SE6440-2UD37-5FA1

1) Supplementary conditions:
Input current at rated operating point, applicable at short-circuit voltage of the supply $U_{sc} = 2\%$ with reference to the inverter rated power and rated mains operating voltage of 240 V or 400 V without a line commutating choke.

2) Acc. to EMC EN 61800-3 generally suited to heavy industrial applications. For details please refer to Appendix on page A/4.

MICROMASTER 440

Selection and ordering data

MICROMASTER 440 inverter without filter³⁾ (continued)

CT (constant torque)			VT (variable torque)				MICROMASTER 440 without filter ³⁾			
Output		Rated input current	Rated output current	Output		Rated input current	Rated output current	Frame size	Weight, approx.	Order No.
kW	hp	A	A	kW	hp	A	A	(FS)	kg	
Mains operating voltage 3 AC 380 V to 480 V										
90	125	169.0 ¹⁾	178	110	150	200.0 ¹⁾	205	FX	116	6SE6440-2UD38-8FA1
110	150	200.0 ¹⁾	205	132	200	245.0 ¹⁾	250	FX	116	6SE6440-2UD41-1FA1
132	200	245.0 ¹⁾	250	160	250	297.0 ¹⁾	302	GX	174	6SE6440-2UD41-3GA1
160	250	297.0 ¹⁾	302	200	300	354.0 ¹⁾	370	GX	174	6SE6440-2UD41-6GA1
200	300	354.0 ¹⁾	370	250	350	442.0 ¹⁾	477	GX	174	6SE6440-2UD42-0GA1
Mains operating voltage 3 AC 500 V to 600 V										
0.75	1.0	2.0 ²⁾	1.4	1.5	2.0	3.2 ²⁾	2.7	C	5.5	6SE6440-2UE17-5CA1
1.5	2.0	3.7 ²⁾	2.7	2.2	3.0	4.4 ²⁾	3.9	C	5.5	6SE6440-2UE21-5CA1
2.2	3.0	5.3 ²⁾	3.9	4.0	5.0	6.9 ²⁾	6.1	C	5.5	6SE6440-2UE22-2CA1
4.0	5.0	8.1 ²⁾	6.1	5.5	7.5	9.4 ²⁾	9	C	5.5	6SE6440-2UE24-0CA1
5.5	7.5	11.1 ²⁾	9	7.5	10	12.6 ²⁾	11	C	5.5	6SE6440-2UE25-5CA1
7.5	10	14.4 ²⁾	11	11.0	15	18.1 ²⁾	17	C	5.5	6SE6440-2UE27-5CA1
11.0	15	21.5 ²⁾	17	15.0	20	24.9 ²⁾	22	C	5.5	6SE6440-2UE31-1CA1
15.0	20	24.9 ²⁾	22	18.5	25	30.0 ²⁾	27	D	16	6SE6440-2UE31-5DA1
18.5	25	30.0 ²⁾	27	22	30	35.0 ²⁾	32	D	16	6SE6440-2UE31-8DA1
22	30	35.0 ²⁾	32	30	40	48.0 ²⁾	41	D	16	6SE6440-2UE32-2DA1
30	40	48.0 ²⁾	41	37	50	58.0 ²⁾	52	E	20	6SE6440-2UE33-0EA1
37	50	58.0 ²⁾	52	45	60	69.0 ²⁾	62	E	20	6SE6440-2UE33-7EA1
45	60	69.0 ²⁾	62	55	75	83.0 ²⁾	77	F	56	6SE6440-2UE34-5FA1
55	75	83.0 ²⁾	77	75	100	113.0 ²⁾	99	F	56	6SE6440-2UE35-5FA1
75	100	113.0 ²⁾	99	90	120	138.0 ²⁾	125	F	56	6SE6440-2UE37-5FA1



See Appendix for note on ordering.

All MICROMASTER 440 inverters are supplied with a Status Display Panel (SDP). A BOP, AOP or other options have to be ordered separately (see Pages 4/16 to 4/22).

Motors for MICROMASTER 440

Catalog D 81.1 contains selection and ordering data for motors which are particularly suitable for operation with the MICROMASTER 440 inverters (see Appendix for overview).

This catalog is suitable for IEC motors. For motors according to US standards (NEMA) please refer to Catalog D 81.2 U.S./Canada (see Appendix for overview) and to: <http://www.sea.siemens.com/motors>

1) Supplementary conditions: Input current at rated operating point, applicable at short-circuit voltage of the supply $U_{sc} \geq 2.33\%$ with reference to the inverter rated power and rated mains operating voltage of 400 V.

2) Supplementary conditions: Input current at rated operating point, applicable at short-circuit voltage of the supply $U_{sc} = 2\%$ with reference to the inverter rated power and rated mains operating voltage of 500 V without a line commutating choke.

3) Acc. to EMC EN 61800-3 generally suited to heavy industrial applications. For details please refer to Appendix on page A/4.

MICROMASTER 440 inverter with internal filter Class A ²⁾

CT (constant torque)			VT (variable torque)				MICROMASTER 440 with internal filter Class A ²⁾			
Output		Rated input current ¹⁾	Rated output current	Output		Rated input current ¹⁾	Rated output current	Frame size (FS)	Weight, approx. kg	Order No.
kW	hp	A	A	kW	hp	A	A			
Mains operating voltage 1 AC 200 V to 240 V										
0.12	0.16	1.8	0.9	–	–	–	–	A	1.3	6SE6440-2AB11-2AA1
0.25	0.33	3.2	1.7	–	–	–	–	A	1.3	6SE6440-2AB12-5AA1
0.37	0.50	4.6	2.3	–	–	–	–	A	1.3	6SE6440-2AB13-7AA1
0.55	0.75	6.2	3.0	–	–	–	–	A	1.3	6SE6440-2AB15-5AA1
0.75	1.0	8.2	3.9	–	–	–	–	A	1.3	6SE6440-2AB17-5AA1
1.1	1.5	11.0	5.5	–	–	–	–	B	3.4	6SE6440-2AB21-1BA1
1.5	2	14.4	7.4	–	–	–	–	B	3.4	6SE6440-2AB21-5BA1
2.2	3	20.2	10.4	–	–	–	–	B	3.4	6SE6440-2AB22-2BA1
3.0	4	35.5	13.6	–	–	–	–	C	5.7	6SE6440-2AB23-0CA1
Mains operating voltage 3 AC 200 V to 240 V										
3.0	4.0	15.6	13.6	–	–	–	–	C	5.7	6SE6440-2AC23-0CA1
4.0	5.0	19.7	17.5	5.5	7.5	28.3	22	C	5.7	6SE6440-2AC24-0CA1
5.5	7.5	26.5	22.0	7.5	10.0	34.2	28	C	5.7	6SE6440-2AC25-5CA1
Mains operating voltage 3 AC 380 V to 480 V										
2.2	3.0	7.5	5.9	–	–	–	–	B	3.4	6SE6440-2AD22-2BA1
3.0	4.0	10.0	7.7	–	–	–	–	B	3.4	6SE6440-2AD23-0BA1
4.0	5.0	12.8	10.2	–	–	–	–	B	3.4	6SE6440-2AD24-0BA1
5.5	7.5	15.6	13.2	7.5	10	17.6	19	C	5.7	6SE6440-2AD25-5CA1
7.5	10	22.0	18.4	11.0	15	23.1	26	C	5.7	6SE6440-2AD27-5CA1
11.0	15	23.1	26	15.0	20	33.8	32	C	5.7	6SE6440-2AD31-1CA1
15.0	20	33.8	32	18.5	25	37.0	38	D	17	6SE6440-2AD31-5DA1
18.5	25	37.0	38	22	30	43.0	45	D	17	6SE6440-2AD31-8DA1
22	30	43.0	45	30	40	59.0	62	D	17	6SE6440-2AD32-2DA1
30	40	59.0	62	37	50	72.0	75	E	22	6SE6440-2AD33-0EA1
37	50	72.0	75	45	60	87.0	90	E	22	6SE6440-2AD33-7EA1
45	60	87.0	90	55	75	104.0	110	F	75	6SE6440-2AD34-5FA1
55	75	104.0	110	75	100	139.0	145	F	75	6SE6440-2AD35-5FA1
75	100	139.0	145	90	125	169.0	178	F	75	6SE6440-2AD37-5FA1



See Appendix for note on ordering.

All MICROMASTER 440 inverters are supplied with a Status Display Panel (SDP). A BOP, AOP or other options have to be ordered separately (see Pages 4/16 to 4/22).

Motors for MICROMASTER 440

Catalog D 81.1 contains selection and ordering data for motors which are particularly suitable for operation with the MICROMASTER 440 inverters (see Appendix for overview).

This catalog is suitable for IEC motors. For motors according to US standards (NEMA) please refer to Catalog D 81.2 U.S./Canada (see Appendix for overview) and to: <http://www.sea.siemens.com/motors>

1) Supplementary conditions:
Input current at rated operating point, applicable at short-circuit voltage of the supply $U_{sc} = 2\%$ with reference to the inverter rated power and rated mains operating voltage of 240 V or 400 V without a line commutating choke.

2) Use of MICROMASTER inverters with internal filter is not permissible on non-grounded mains supplies.

MICROMASTER 440

Options Variant dependent options

Overview

EMC filter, Class A

Filter for inverters without an internal filter for

- 3 AC 200 V to 240 V, frame sizes A and B
- 3 AC 380 V to 480 V, frame size A, FX, GX

Filters for frame sizes FX and GX are only permitted to be used in combination with a line commutating choke.

All other inverters with the exception of inverters for 500 V to 600 V can be supplied with an internal Class A filter.

The requirements are fulfilled using shielded cables with a max. length of 25 m.

EMC filter, Class B

Filter for inverters without an internal filter for

- 3 AC 200 V to 240 V, frame sizes A and B
- 3 AC 380 V to 480 V, frame size A.

The requirements are fulfilled using shielded cables with a max. length of 25 m.

For inverters 15 kW to 75 kW without filters, EMC filters of Class B from Schaffner can be used.

The requirements are fulfilled using shielded cables with a max. length of 25 m to 50 m (depending on the type, details on request).

With this filter, the inverter complies with the emission standard EN 55 011, Class B for conducted interference emissions.

Additional EMC filter, Class B

Available for inverters with an internal Class A EMC filter, frame sizes A, B and C.

The requirements are fulfilled using shielded cables with a max. length of 25 m.

With this filter, the inverter complies with the emission standard EN 55 011, Class B for conducted interference emissions.

Filter Class B with low leakage currents

EMC filter for 1 AC 200 V to 240 V inverters, frame sizes A and B, without an internal EMC filter Class A.

With this filter, the inverter complies with the emission standard EN 55 011, Class B for conducted interference emissions. The leakage currents are reduced to < 3.5 mA.

The requirements are fulfilled using shielded cables with a max. length of 5 m.

Leakage currents:

The leakage currents of the inverters with/without filter (internal/external) may exceed 30 mA. Typical values in practice are between 10 mA and 50 mA. The exact values depend on the design, environment and cable lengths. Interference-free operation with residual current operated devices with a trigger value of 30 mA cannot be guaranteed. However, operation with residual current circuit-breakers with a trigger value of 300 mA is possible. Please refer to the Instruction Manual for details.

LC filter and sinusoidal filter

The LC filter/sinusoidal filter limits the rate of rise of voltage and the capacitive charge/discharge currents which usually occur with inverter operation. This means that much longer shielded motor cables are possible when using LC filters/sinusoidal filters and the service life of the motor achieves values similar to those with direct mains operation. Use of an output choke isn't required with that.

Please note when using LC filters/sinusoidal filters:

- Only V/f, FCC control permissible
- Please observe the derating of 15 % when selecting the appropriate inverter
- Operation only permissible with 4 kHz pulse frequency
Note: Please observe derating for frame sizes FX and GX.
- The output frequency is limited to 150 Hz
- Operation and commissioning only with connected motor as the LC filter/sinusoidal filter is not idling-proof!

The LC filters/sinusoidal filters can be used for all MICROMASTER 440 inverters of frame sizes A to GX.

- Frame sizes D to F:
The LC filters, frame sizes D to F, are designed for mounting upright in the control cabinet. Due to leakage flux lines caused by physical sources, a minimum distance of 50 mm to adjacent modules and metal parts is recommended.
- Frame sizes FX and GX:
The sinusoidal filters, frame sizes FX and GX, are designed for mounting upright in the control cabinet. Due to leakage flux lines caused by physical sources, a minimum distance of 100 mm to adjacent modules and metal parts is recommended.

Technical data

LC filter and sinusoidal filter

Mains voltage	3 AC 380 V to 480 V	3 AC 500 V to 600 V
Current (at 40 °C/50 °C)		
For frame size A (0.37 to 1.5 kW)	4.5 A/4.1 A	–
For frame size B (2.2 to 4 kW)	11.2 A/10.2 A	–
For frame size C (0.75 to 4 kW)	–	9.0 A/6.1 A
For frame size C (5.5 to 11 kW)	32.6 A/26 A	22.4 A/17 A
For frame size D (15 kW)	38.8 A/32 A	27.5 A/22 A
For frame size D (18.5 kW)	45.9 A/38 A	32.6 A/27 A
For frame size D (22 kW)	63.2 A/45 A	41.8 A/32 A
For frame size E (30 kW)	76.5 A/62 A	53 A/41 A
For frame size E (37 kW)	112.2 A/90 A	63.2 A/52 A
For frame size F (45 kW)	112.2 A/90 A	78.5 A/62 A
For frame size F (55 kW)	147.9 A/110 A	101 A/77 A
For frame size F (75 kW)	181.6 A/145 A	127.5 A/99 A
Current (at 40 °C/55 °C)		
For frame size FX (90 kW and 110 kW)	225 A/191 A	–
For frame size GX (132 kW)	276 A/235 A	–
For frame size GX (160 kW)	333 A/283 A	–
For frame size GX (200 kW)	408 A/347 A	–

Technical data (continued)

LC filter and sinusoidal filter

Limiting of motor overvoltage		≤ 1078 V	
dV/dt limiting		≤ 500 V/μs	
Pulse frequency		4 kHz	
Max. motor frequency		150 Hz	
Max. permissible motor cable lengths			
For frame sizes A to F	shielded	200 m	
	unshielded	300 m	
For frame sizes FX and GX	shielded	300 m	
	unshielded	450 m	
Insulation strength		Overvoltage category III to VDE 0110	
Electromagnetic compatibility		Up to 200 m motor cable length with emissions to Class A according to EN 55 011 in conjunction with filtered inverters and unshielded cables	
For frame sizes A to F		Up to 150 m motor cable length with emissions to Class A according to EN 55 011 in conjunction with filtered inverters and unshielded cables	
For frame sizes FX and GX			
Conformity		CE according to the low-voltage directive 73/23/EEC	
Approvals		cUL E 219022	
Strain resistance		EN 60 068-2-31	
Humidity		95 % humidity, non-condensing	
Degree of protection		IP20 (to EN 60 529)	
For frame sizes A to C		IP00/IP20 (to EN 60 529 with terminal covers)	
For frame sizes D to F		IP00	
For frame sizes FX and GX			
Insulation class		H (180 °C)	
Temperature range			
For frame sizes A to F	Operation	-10 °C to +40 °C (+14 °F to +104 °F) to +50 °C (to +122 °F)	100 % P _n 80 % P _n
	Storage	-25 °C to +70 °C (-13 °F to +158 °F)	
For frame sizes FX and GX	Operation	-10 °C to +40 °C (+14 °F to +104 °F) to +55 °C (to +131 °F)	100 % P _n 85 % P _n
	Storage	-40 °C to +70 °C (-40 °F to +158 °F)	
Installation altitude			
For frame sizes A to C		Up to 2000 m: 100 % P _n	
		2000 to 4000 m: 62.5 % P _n	
For frame sizes D to F		Up to 1000 m: 100 % P _n	
		1000 to 4000 m: 12.5 % derating for each 1000 m	
For frame sizes FX and GX		Up to 2000 m: 100 % P _n	
		2000 to 4000 m: 7.5 % derating for each 1000 m	
Mounting position		Footprint or suspended upright	
For frame sizes A to C			
For frame sizes D to F, FX and GX			
Ventilation clearances			
For frame sizes A to C	Top	100 mm	
	Bottom	100 mm	
	Side	100 mm	
For frame sizes D to F, FX and GX	Top	100 mm	
	Side	100 mm	
Connection system	Input, litz wire or terminal	1U1, 1V1, 1W1	
	Output, terminals	1U2, 1V2, 1W2	
Torque for conductor connections		Terminal cross-section	Torque
For frame sizes A to C		-	1.5 Nm to 1.8 Nm
For frame sizes D to F		16 mm ²	2.0 Nm to 4.0 Nm
		35 mm ²	2.5 Nm to 5.0 Nm
		50 mm ²	3.0 Nm to 6.0 Nm
		95 mm ²	6.0 Nm to 12.0 Nm
		150 mm ²	10.0 Nm to 20.0 Nm
For frame sizes FX and GX		-	14.0 Nm to 31.0 Nm
Weight, approx.			
For frame size A		7 kg	
For frame size B		11 kg	
For frame size C		8.5 kg to 29 kg	
For frame size D		21 kg to 42 kg	
For frame size E		49.5 kg to 67 kg	
For frame size F		67 kg to 126 kg	
For frame size FX		135 kg	
For frame size GX		138 kg to 208 kg	

MICROMASTER 440

Options

Variant dependent options

Overview

Line commutating choke

Line commutating chokes are used to smooth voltage peaks or to bridge commutating dips. In addition, line commutating chokes reduce the effects of harmonics on the inverter and the power supply. If the line impedance is $< 1\%$, a line commutating choke must be used in order to reduce the current peaks.

In line with EN 61 000-3-2 regulations "Limits for harmonic currents with device input current ≤ 16 A per phase", there are special aspects for drives with 250 W to 550 W and 230 V single-phase supplies which can be used in non-industrial applications (1st environment).

For devices with 250 W and 350 W, it is necessary either to fit the recommended input chokes or to apply to the power utility company for authorization to connect the devices to the public power supply.

No limits are currently defined in the EN 61 000-3-2 standard for professionally used devices with a connected load > 1 kW which means that the inverters with an output power ≥ 0.75 kW comply with the EN 61 000-3-2 standard.

However, in accordance with the regulations of EN 61000-3-12 "Limits for harmonic currents > 16 A and ≤ 75 A per phase" an approval is necessary from the power supplier for drives that are intended to be connected to the public low-voltage network. Please refer to the Operating Instructions for the values of the harmonic currents.

Output choke

Output chokes can be supplied for reducing the capacitive compensation currents and dV/dt in the case of motor cables > 50 m (shielded) or > 100 m (unshielded).

For max. permissible cable lengths, see the Technical Data.

Brake resistors

The brake resistors are designed for use with the MICROMASTER 440 inverter series, frame sizes A to F, with internal brake chopper and enable loads with a large moment of inertia to be braked quickly. During braking of the motor and the load, excess energy is fed back to the inverter. This causes the voltage to rise in the DC link. The inverter transfers the excess energy to the externally mounted braking resistor.

For MICROMASTER 440 inverters of frame sizes FX and GX, external SIMOVERT MASTERDRIVES brake units and the appropriate brake resistors can be used (see Catalog DA 65.10).

Gland plate

Gland plates are available for inverters of frame sizes A, B and C. All the other frame sizes have the shield connection for the control cable integrated in the inverter.

The shield for the power cable has to be connected externally (e.g. in the control cabinet). Exception: Inverters of frame sizes D and E and frame size F with integrated class A filter. In this case the shield connection is integrated in the inverter.

The gland plate enables the shields of the power and control cables to be terminated ensuring optimum EMC performance.

Technical data

Max. permissible cable lengths from the motor to the inverter when using output chokes

The following table shows the maximum permissible cable lengths from the motor to the inverter when using output chokes.

Note:

Operation up to 150 Hz output frequency only!

Frame size (FS)	Output choke Type	Max. permissible motor cable lengths (shielded/unshielded) for a mains voltage of			
		200 V to 240 V $\pm 10\%$	380 V to 400 V $\pm 10\%$	401 V to 480 V $\pm 10\%$	500 V to 600 V $\pm 10\%$
A	6SE6400-3TC00-4AD3	200 m/300 m	–	–	–
A	6SE6400-3TC00-4AD2	–	150 m/225 m	100 m/150 m	–
B	6SE6400-3TC01-0BD3	200 m/300 m	150 m/225 m	100 m/150 m	–
C	6SE6400-3TC03-2CD3	200 m/300 m	200 m/300 m	100 m/150 m	–
C	6SE6400-3TC01-8CE3	–	–	–	100 m/150 m
D to F	6SE6400-3TC.	200 m/300 m	200 m/300 m	200 m/300 m	200 m/300 m
FX	6SL3000-2BE32-1AA0	–	300 m/450 m	300 m/450 m	–
FX	6SL3000-2BE32-6AA0	–	300 m/450 m	300 m/450 m	–
GX	6SL3000-2BE33-2AA0	–	300 m/450 m	300 m/450 m	–
GX	6SL3000-2BE33-8AA0	–	300 m/450 m	300 m/450 m	–
GX	6SL3000-2BE35-0AA0	–	300 m/450 m	300 m/450 m	–

Options Variant dependent options

Design

General installation instructions

- A maximum of two footprint components plus inverter are permissible.
- If an LC filter is used, it must, if possible, be mounted directly on the wall of the control cabinet due to weight reasons. If an LC filter of frame size C is used, therefore, only one footprint component is permissible. If a line choke and LC filter are used, the line choke must be located on the left of the inverter. Required distance between line choke and inverter: 75 mm.
- The EMC filter must be mounted directly below the frequency inverter if possible.
- If mounted on the side, the line-side components are to be mounted to the left of the frequency inverter whereas the output-side components are to be mounted to the right of the frequency inverter.
- If a braking resistor is used, it must, if possible, be mounted directly on the wall of the control cabinet due to reasons relating to temperature increases.

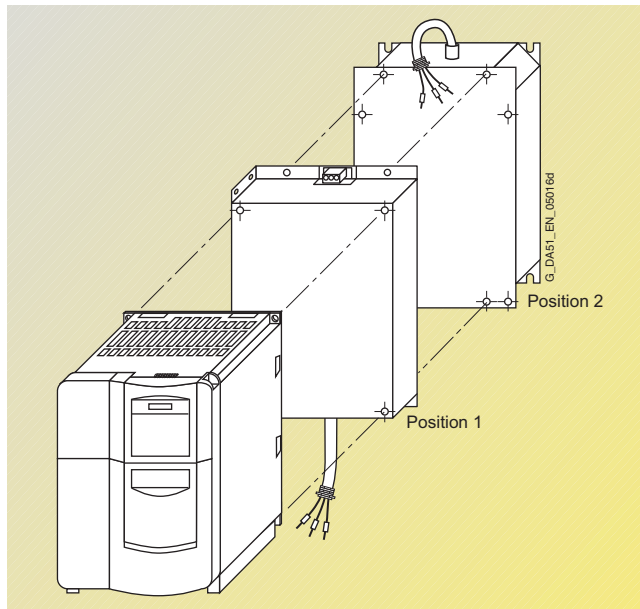

Example of installation with frequency inverter, EMC filter (position 1) and line choke (position 2)

Availability of the options as footprint components

	Frame size									
	A	B	C	D	E	F	G	FX	GX	
Line commutating choke	✓	✓	✓	✓	✓					
EMC filter	✓	✓	✓							
LC filter	✓	✓	✓							
Output choke	✓	✓	✓							
Braking resistor	✓	✓								

Recommended combinations of inverters and options

Frequency inverter Frame size	Footprint		Mounted on side	
	Position 1	Position 2	To the left of the inverter (for line-side components)	To the right of the inverter (for output-side components)
A and B	EMC filter	Line commutating choke	–	Output choke <u>and/or</u> Braking resistor
	EMC filter <u>or</u> Line commutating choke	Output choke <u>or</u> LC filter	–	Braking resistor
	EMC filter <u>or</u> Line commutating choke	Braking resistor	–	–
	EMC filter <u>or</u> Line commutating choke <u>or</u> Braking resistor	–	–	–
C	EMC filter	Line commutating choke	–	Output choke <u>and/or</u> Braking resistor
	EMC filter <u>or</u> Line commutating choke	Output choke	–	Braking resistor
	LC filter	–	EMC filter <u>and/or</u> Line commutating choke	Braking resistor
D and E	Line commutating choke	–	EMC filter	Output choke <u>or</u> LC filter <u>and/or</u> Braking resistor
F, G, FX and GX	–	–	EMC filter <u>and/or</u> Line commutating choke	Output choke <u>or</u> LC filter <u>and/or</u> Braking resistor

MICROMASTER 440

Options

Variant dependent options

Selection and ordering data

The options listed here (filters, chokes, brake resistors, gland plates, fuses and circuit-breakers) must be selected to match the respective inverter.

The inverter and the associated options have the same voltage ratings. Alternatively fuses and circuit-breakers can be provided. Both provide short

circuit protection of the inverter supply line and the inverter. A semiconductor protection of the inverter with the suggested 3NA... fuses and the

3RV.../3VL... circuit-breakers is not envisaged.

*) Must be used in combination with a line commutating choke.

Mains voltage	Output (CT)		Inverter without filter	Order No. of the options		
	kW	hp		EMC filter, Class A	EMC filter, Class B	Line commutating choke
1 AC 200 V to 240 V	0.12	0.16	6SE6440-2UC11-2AA1	–	6SE6400-2FL01-0AB0	6SE6400-3CC00-4AB3
	0.25	0.33	6SE6440-2UC12-5AA1	–	with low leakage currents	
	0.37	0.50	6SE6440-2UC13-7AA1	–		6SE6400-3CC01-0AB3
	0.55	0.75	6SE6440-2UC15-5AA1	–		
	0.75	1.0	6SE6440-2UC17-5AA1	–		
	1.1	1.5	6SE6440-2UC21-1BA1	–	6SE6400-2FL02-6BB0	6SE6400-3CC02-6BB3
	1.5	2.0	6SE6440-2UC21-5BA1	–	with low leakage currents	
	2.2	3.0	6SE6440-2UC22-2BA1	–		
	3.0	4.0	6SE6440-2UC23-0CA1	–	–	6SE6400-3CC03-5CB3
	3 AC 200 V to 240 V	0.12	0.16	6SE6440-2UC11-2AA1	6SE6400-2FA00-6AD0	6SE6400-2FB00-6AD0
0.25		0.33	6SE6440-2UC12-5AA1			
0.37		0.50	6SE6440-2UC13-7AA1			6SE6400-3CC00-5AC3
0.55		0.75	6SE6440-2UC15-5AA1			
0.75		1.0	6SE6440-2UC17-5AA1			
1.1		1.5	6SE6440-2UC21-1BA1	6SE6400-2FA01-4BC0	6SE6400-2FB01-4BC0	6SE6400-3CC00-8BC3
1.5		2.0	6SE6440-2UC21-5BA1			6SE6400-3CC01-4BD3
2.2		3.0	6SE6440-2UC22-2BA1			
3.0		4.0	6SE6440-2UC23-0CA1	–	–	6SE6400-3CC01-7CC3
4.0		5.0	6SE6440-2UC24-0CA1	–	–	6SE6400-3CC03-5CD3
5.5		7.5	6SE6440-2UC25-5CA1	–	–	
7.5		10	6SE6440-2UC27-5DA1	–	–	6SE6400-3CC05-2DD0
11.0		15	6SE6440-2UC31-1DA1	–	–	
15.0		20	6SE6440-2UC31-5DA1	–	–	
18.5		25	6SE6440-2UC31-8EA1	–	–	6SE6400-3CC08-8EC0
22		30	6SE6440-2UC32-2EA1	–	–	
30		40	6SE6440-2UC33-0FA1	–	–	6SE6400-3CC11-7FD0
37		50	6SE6440-2UC33-7FA1	–	–	
45		60	6SE6440-2UC34-5FA1	–	–	
3 AC 380 V to 480 V		0.37	0.50	6SE6440-2UD13-7AA1	6SE6400-2FA00-6AD0	6SE6400-2FB00-6AD0
	0.55	0.75	6SE6440-2UD15-5AA1			
	0.75	1.0	6SE6440-2UD17-5AA1			6SE6400-3CC00-4AD3
	1.1	1.5	6SE6440-2UD21-1AA1			
	1.5	2.0	6SE6440-2UD21-5AA1			6SE6400-3CC00-6AD3
	2.2	3.0	6SE6440-2UD22-2BA1	–	–	6SE6400-3CC01-0BD3
	3.0	4.0	6SE6440-2UD23-0BA1	–	–	
	4.0	5.0	6SE6440-2UD24-0BA1	–	–	6SE6400-3CC01-4BD3
	5.5	7.5	6SE6440-2UD25-5CA1	–	–	6SE6400-3CC02-2CD3
	7.5	10	6SE6440-2UD27-5CA1	–	–	
	11.0	15	6SE6440-2UD31-1CA1	–	–	6SE6400-3CC03-5CD3
	15.0	20	6SE6440-2UD31-5DA1	–	–	6SE6400-3CC04-4DD0
	18.5	25	6SE6440-2UD31-8DA1	–	EMC filter, Class B, available from Schaffner	
	22	30	6SE6440-2UD32-2DA1	–		6SE6400-3CC05-2DD0
	30	40	6SE6440-2UD33-0EA1	–		6SE6400-3CC08-3ED0
	37	50	6SE6440-2UD33-7EA1	–		
	45	60	6SE6440-2UD34-5FA1	–		6SE6400-3CC11-2FD0
	55	75	6SE6440-2UD35-5FA1	–		
	75	100	6SE6440-2UD37-5FA1	–		6SE6400-3CC11-7FD0
	90	125	6SE6440-2UD38-8FA1	6SL3000-0BE32-5AA0 *)	–	6SL3000-0CE32-3AA0
110	150	6SE6440-2UD41-1FA1	6SL3000-0BE34-4AA0 *)	–	6SL3000-0CE32-8AA0	
132	200	6SE6440-2UD41-3GA1	–	–	6SL3000-0CE33-3AA0	
160	250	6SE6440-2UD41-6GA1	–	–	6SL3000-0CE35-1AA0	
200	300	6SE6440-2UD42-0GA1	6SL3000-0BE36-0AA0 *)	–		
3 AC 500 V to 600 V	0.75	1.0	6SE6440-2UE17-5CA1	–	–	6SE6400-3CC00-4CE3
	1.5	2.0	6SE6440-2UE21-5CA1	–	–	
	2.2	3.0	6SE6440-2UE22-2CA1	–	–	6SE6400-3CC00-8CE3
	4.0	5.0	6SE6440-2UE24-0CA1	–	–	
	5.5	7.5	6SE6440-2UE25-5CA1	–	–	6SE6400-3CC02-4CE3
	7.5	10	6SE6440-2UE27-5CA1	–	–	
	11.0	15	6SE6440-2UE31-1CA1	–	–	
	15.0	20	6SE6440-2UE31-5DA1	–	–	6SE6400-3CC04-4DD0
	18.5	25	6SE6440-2UE31-8DA1	–	–	
	22	30	6SE6440-2UE32-2DA1	–	–	
	30	40	6SE6440-2UE33-0EA1	–	–	6SE6400-3CC08-3ED0
	37	50	6SE6440-2UE33-7EA1	–	–	
	45	60	6SE6440-2UE34-5FA1	–	–	6SE6400-3CC11-2FD0
	55	75	6SE6440-2UE35-5FA1	–	–	
75	100	6SE6440-2UE37-5FA1	–	–		

Selection and ordering data (continued)

All options are certified to
UL, except fuses.
The 3NE1 fuses are UL-listed
(equivalent to FUL).

Additional information on
the listed fuses and circuit-
breakers can be found in
Catalogs LV 1 and LV 1 T.

Mains voltage	Output (CT)		Inverter without filter	Order No. of the options LC/sinusoidal filter	Output choke	Brake resistors
	kW	hp				
1 AC 200 V to 240 V	0.12	0.16	6SE6440-2UC11-2AA1	–	6SE6400-3TC00-4AD3	6SE6400-4BC05-0AA0
	0.25	0.33	6SE6440-2UC12-5AA1	–		
	0.37	0.50	6SE6440-2UC13-7AA1	–		
	0.55	0.75	6SE6440-2UC15-5AA1	–		
	0.75	1.0	6SE6440-2UC17-5AA1	–		
	1.1	1.5	6SE6440-2UC21-1BA1	–	6SE6400-3TC01-0BD3	6SE6400-4BC11-2BA0
	1.5	2.0	6SE6440-2UC21-5BA1	–		
	2.2	3.0	6SE6440-2UC22-2BA1	–		
	3.0	4.0	6SE6440-2UC23-0CA1	–	6SE6400-3TC03-2CD3	6SE6400-4BC12-5CA0
	3.0	4.0	6SE6440-2UC24-0CA1	–	6SE6400-3TC00-4AD3	6SE6400-4BC05-0AA0
3 AC 200 V to 240 V	0.12	0.16	6SE6440-2UC11-2AA1	–		
	0.25	0.33	6SE6440-2UC12-5AA1	–		
	0.37	0.50	6SE6440-2UC13-7AA1	–		
	0.55	0.75	6SE6440-2UC15-5AA1	–		
	0.75	1.0	6SE6440-2UC17-5AA1	–		
	1.1	1.5	6SE6440-2UC21-1BA1	–	6SE6400-3TC01-0BD3	6SE6400-4BC11-2BA0
	1.5	2.0	6SE6440-2UC21-5BA1	–		
	2.2	3.0	6SE6440-2UC22-2BA1	–		
	3.0	4.0	6SE6440-2UC23-0CA1	–	6SE6400-3TC03-2CD3	6SE6400-4BC12-5CA0
	4.0	5.0	6SE6440-2UC24-0CA1	–		6SE6400-4BC13-0CA0
	5.5	7.5	6SE6440-2UC25-5CA1	–		
	7.5	10	6SE6440-2UC27-5DA1	–	6SE6400-3TC05-4DD0	6SE6400-4BC18-0DA0
	11.0	15	6SE6440-2UC31-1DA1	–		
	15.0	20	6SE6440-2UC31-5DA1	–		
	18.5	25	6SE6440-2UC31-8EA1	–	6SE6400-3TC08-0ED0	6SE6400-4BC21-2EA0
	22	30	6SE6440-2UC32-2EA1	–		
	30	40	6SE6440-2UC33-0FA1	–	6SE6400-3TC15-4FD0	6SE6400-4BC22-5FA0
	37	50	6SE6440-2UC33-7FA1	–		
45	60	6SE6440-2UC34-5FA1	–			
3 AC 380 V to 480 V	0.37	0.50	6SE6440-2UD13-7AA1	6SE6400-3TD00-4AD0	6SE6400-3TC00-4AD2	6SE6400-4BD11-0AA0
	0.55	0.75	6SE6440-2UD15-5AA1			
	0.75	1.0	6SE6440-2UD17-5AA1			
	1.1	1.5	6SE6440-2UD21-1AA1			
	1.5	2.0	6SE6440-2UD21-5AA1			
	2.2	3.0	6SE6440-2UD22-2BA1	6SE6400-3TD01-0BD0	6SE6400-3TC01-0BD3	6SE6400-4BD12-0BA0
	3.0	4.0	6SE6440-2UD23-0BA1			
	4.0	5.0	6SE6440-2UD24-0BA1			
	5.5	7.5	6SE6440-2UD25-5CA1	6SE6400-3TD03-2CD0	6SE6400-3TC03-2CD3	6SE6400-4BD16-5CA0
	7.5	10	6SE6440-2UD27-5CA1			
	11.0	15	6SE6440-2UD31-1CA1			
	15.0	20	6SE6440-2UD31-5DA1	6SE6400-3TD03-7DD0	6SE6400-3TC05-4DD0	6SE6400-4BD21-2DA0
	18.5	25	6SE6440-2UD31-8DA1	6SE6400-3TD04-8DD0	6SE6400-3TC03-8DD0	
	22	30	6SE6440-2UD32-2DA1	6SE6400-3TD06-1DD0	6SE6400-3TC05-4DD0	
	30	40	6SE6440-2UD33-0EA1	6SE6400-3TD07-2ED0	6SE6400-3TC08-0ED0	6SE6400-4BD22-2EA0
	37	50	6SE6440-2UD33-7EA1	6SE6400-3TD11-5FD0	6SE6400-3TC07-5ED0	
	45	60	6SE6440-2UD34-5FA1		6SE6400-3TC14-5FD0	6SE6400-4BD24-0FA0
	55	75	6SE6440-2UD35-5FA1	6SE6400-3TD15-0FD0	6SE6400-3TC15-4FD0	
	75	100	6SE6440-2UD37-5FA1	6SE6400-3TD18-0FD0	6SE6400-3TC14-5FD0	
	90	125	6SE6440-2UD38-8FA1	6SL3000-2CE32-3AA0	6SL3000-2BE32-1AA0	–
110	150	6SE6440-2UD41-1FA1		6SL3000-2BE32-6AA0	–	
132	200	6SE6440-2UD41-3GA1	6SL3000-2CE32-8AA0	6SL3000-2BE33-2AA0	–	
160	250	6SE6440-2UD41-6GA1	6SL3000-2CE33-3AA0	6SL3000-2BE33-8AA0	–	
200	300	6SE6440-2UD42-0GA1	6SL3000-2CE34-1AA0	6SL3000-2BE35-0AA0	–	
3 AC 500 V to 600 V	0.75	1.0	6SE6440-2UE17-5CA1	6SE6400-3TD01-0CE0	6SE6400-3TC01-8CE3	6SE6400-4BE14-5CA0
	1.5	2.0	6SE6440-2UE21-5CA1			
	2.2	3.0	6SE6440-2UE22-2CA1			
	4.0	5.0	6SE6440-2UE24-0CA1			
	5.5	7.5	6SE6440-2UE25-5CA1	6SE6400-3TD02-3CE0		
	7.5	10	6SE6440-2UE27-5CA1			6SE6400-4BE16-5CA0
	11.0	15	6SE6440-2UE31-1CA1			
	15.0	20	6SE6440-2UE31-5DA1	6SE6400-3TD02-3DE0	6SE6400-3TC03-2DE0	6SE6400-4BE21-3DA0
	18.5	25	6SE6440-2UE31-8DA1	6SE6400-3TD03-2DE0		
	22	30	6SE6440-2UE32-2DA1	6SE6400-3TD03-7DE0		
	30	40	6SE6440-2UE33-0EA1	6SE6400-3TD04-8EE0	6SE6400-3TC06-2FE0	6SE6400-4BE21-8EA0
	37	50	6SE6440-2UE33-7EA1	6SE6400-3TD06-1EE0		
	45	60	6SE6440-2UE34-5FA1	6SE6400-3TD07-1FE0		6SE6400-4BE24-2FA0
	55	75	6SE6440-2UE35-5FA1	6SE6400-3TD10-0FE0	6SE6400-3TC08-8FE0	
	75	100	6SE6440-2UE37-5FA1	6SE6400-3TD11-5FE0		

MICROMASTER 440

Options
Variant dependent options

Selection and ordering data (continued)

● Use in America requires @-listed fuses such as the Class NON/NOS range from Bussmann.

Mains voltage	Output (CT)		Inverter without filter	Order No. of options Gland plate	Fuses (see LV 1)		Circuit-breaker (see Catalog LV 1)			
	kW	hp			3NA3	3NE1 (VA)				
1 AC 200 V to 240 V	0.12	0.16	6SE6440-2UC11-2AA1	6SE6400-0GP00-0AA0	3NA3803	●	3RV1021-1EA10			
	0.25	0.33	6SE6440-2UC12-5AA1				3RV1021-1HA10			
	0.37	0.50	6SE6440-2UC13-7AA1				3RV1021-1JA10			
	0.55	0.75	6SE6440-2UC15-5AA1	6SE6400-0GP00-0BA0	3NA3805	3RV1021-1KA10	3RV1021-4AA10			
	0.75	1.0	6SE6440-2UC17-5AA1				3RV1021-1KA10			
	1.1	1.5	6SE6440-2UC21-1BA1				3RV1021-4DA10			
	1.5	2.0	6SE6440-2UC21-5BA1	6SE6400-0GP00-0CA0	3NA3807	3RV1021-4DA10	3RV1031-4EA10			
	2.2	3.0	6SE6440-2UC22-2BA1				3RV1031-4FA10			
	3.0	4.0	6SE6440-2UC23-0CA1				3RV1041-4JA10			
	3 AC 200 V to 240 V	0.12	0.16	6SE6440-2UC11-2AA1	6SE6400-0GP00-0AA0	3NA3803	●	3RV1021-1BA10		
0.25		0.33	6SE6440-2UC12-5AA1	3RV1021-1DA10						
0.37		0.50	6SE6440-2UC13-7AA1	3RV1021-1FA10						
0.55		0.75	6SE6440-2UC15-5AA1	6SE6400-0GP00-0BA0	3NA3805	3RV1021-1GA10	3RV1021-1HA10			
0.75		1.0	6SE6440-2UC17-5AA1				3RV1021-1KA10			
1.1		1.5	6SE6440-2UC21-1BA1				3RV1021-1KA10			
1.5		2.0	6SE6440-2UC21-5BA1	6SE6400-0GP00-0CA0	3NA3807	3RV1021-1KA10	3RV1021-4AA10			
2.2		3.0	6SE6440-2UC22-2BA1				3RV1021-4CA10			
3.0		4.0	6SE6440-2UC23-0CA1				3RV1031-4EA10			
4.0		5.0	6SE6440-2UC24-0CA1	6SE6400-0GP00-0CA0	3NA3810	3RV1021-4CA10	3RV1031-4FA10			
5.5		7.5	6SE6440-2UC25-5CA1				3RV1031-4HA10			
7.5		10	6SE6440-2UC27-5DA1				3RV1042-4JA10			
11.0		15	6SE6440-2UC31-1DA1	Integrated as standard for shield connection of the control cable and the power cable.	3NA3820	3NE1817-0	3RV1042-4LA10	3VL1712-.DD33-....		
15.0		20	6SE6440-2UC31-5DA1					3NA3824	3NE1820-0	3RV1042-4LA10
18.5		25	6SE6440-2UC31-8EA1					3NA3830	3NE1021-0	3RV1042-4LA10
22		30	6SE6440-2UC32-2EA1	Integrated as standard for shield connection of the control cable. The shield of the power cable has to be connected externally (e.g. in the control cabinet).	3NA3832	3NE1022-0	3RV1042-4LA10	3VL1716-.DD33-....		
30		40	6SE6440-2UC33-0FA1					3NA3140	3NE1225-0	3VL3725-.DC36-....
37		50	6SE6440-2UC33-7FA1					3NA3142	3NE1225-0	3VL4731-.DC36-....
45		60	6SE6440-2UC34-5FA1	6SE6400-0GP00-0CA0	3NA3144	3NE1227-0	3RV1031-4HA10			
3 AC 380 V to 480 V		0.37	0.50	6SE6440-2UD13-7AA1	6SE6400-0GP00-0AA0	3NA3803	●	3RV1021-1CA10		
	0.55	0.75	6SE6440-2UD15-5AA1	3RV1021-1DA10						
	0.75	1.0	6SE6440-2UD17-5AA1	3RV1021-1FA10						
	1.1	1.5	6SE6440-2UD21-1AA1	6SE6400-0GP00-0BA0	3NA3805	3RV1021-1GA10	3RV1021-1GA10			
	1.5	2.0	6SE6440-2UD21-5AA1				3RV1021-1JA10			
	2.2	3.0	6SE6440-2UD22-2BA1				3RV1021-1KA10			
	3.0	4.0	6SE6440-2UD23-0BA1	6SE6400-0GP00-0CA0	3NA3807	3RV1021-4AA10	3RV1021-4AA10			
	4.0	5.0	6SE6440-2UD24-0BA1				3RV1021-4BA10			
	5.5	7.5	6SE6440-2UD25-5CA1				3RV1031-4EA10			
	7.5	10	6SE6440-2UD27-5CA1	6SE6400-0GP00-0CA0	3NA3812	3RV1031-4FA10	3RV1031-4FA10			
	11.0	15	6SE6440-2UD31-1CA1				3NA3814	3RV1031-4HA10		
	15.0	20	6SE6440-2UD31-5DA1				3NA3820	3NE1817-0	3RV1042-4KA10	
	18.5	25	6SE6440-2UD31-8DA1	Integrated as standard for shield connection of the control cable and the power cable.	3NA3822	3NE1818-0	3RV1042-4MA10	3VL1712-.DD33-....		
	22	30	6SE6440-2UD32-2DA1					3NA3824	3NE1820-0	3RV1042-4MA10
	30	40	6SE6440-2UD33-0EA1					3NA3830	3NE1021-0	3VL1712-.DD33-....
	37	50	6SE6440-2UD33-7EA1	Integrated as standard for shield connection of the control cable. The shield of the power cable has to be connected externally (e.g. in the control cabinet).	3NA3832	3NE1022-0	3RV1042-4MA10	3VL1716-.DD33-....		
	45	60	6SE6440-2UD34-5FA1					3NA3836	3NE1224-0	3VL3720-.DC36-....
	55	75	6SE6440-2UD35-5FA1					3NA3140	3NE1225-0	3VL3725-.DC36-....
	75	100	6SE6440-2UD37-5FA1	Integrated as standard for shield connection of the control cable. The shield of the power cable has to be connected externally (e.g. in the control cabinet).	3NA3144	3NE1227-0	3RV1042-4MA10	3VL3725-.DC36-....		
	90	125	6SE6440-2UD38-8FA1					3NA3144	3NE1227-0	3VL4731-.DC36-....
110	150	6SE6440-2UD41-1FA1	-					3NE1230-0	3RV1031-4HA10	
132	200	6SE6440-2UD41-3GA1	-	3NE1332-0	3RV1031-4HA10					
160	250	6SE6440-2UD41-6GA1	-	3NE1333-0	3VL4740-.DC36-....					
200	300	6SE6440-2UD42-0GA1	-	3NE1435-0	3VL5750-.DC36-....					
3 AC 500 V to 600 V	0.75	1.0	6SE6440-2UE17-5CA1	6SE6400-0GP00-0CA0	3NA3803-6	●	3RV1021-1EA10			
	1.5	2.0	6SE6440-2UE21-5CA1				3RV1021-1GA10			
	2.2	3.0	6SE6440-2UE22-2CA1				3RV1021-1JA10			
	4.0	5.0	6SE6440-2UE24-0CA1	6SE6400-0GP00-0CA0	3NA3805-6	3RV1021-4AA10	3RV1021-4AA10			
	5.5	7.5	6SE6440-2UE25-5CA1				3RV1021-4BA10			
	7.5	10	6SE6440-2UE27-5CA1				3RV1021-4DA10			
	11.0	15	6SE6440-2UE31-1CA1	6SE6400-0GP00-0CA0	3NA3810-6	3RV1021-4DA10	3RV1021-4DA10			
	15.0	20	6SE6440-2UE31-5DA1				3NA3812-6	3RV1031-4FA10		
	18.5	25	6SE6440-2UE31-8DA1				3NA3814-6	3NE1803-0	3RV1031-4HA10	
	22	30	6SE6440-2UE32-2DA1	Integrated as standard for shield connection of the control cable and the power cable.	3NA3820-6	3NE1817-0	3RV1042-4JA10	3RV1042-4JA10		
	30	40	6SE6440-2UE33-0EA1					3NA3822-6	3NE1818-0	3RV1042-4KA10
	37	50	6SE6440-2UE33-7EA1					3NA3824-6	3NE1820-0	3RV1042-4MA10
	45	60	6SE6440-2UE34-5FA1	Integrated as standard for shield connection of the control cable. The shield of the power cable has to be connected externally (e.g. in the control cabinet).	3NA3132-6	3NE1022-0	3RV1042-4MA10	3VL1712-.DD33-....		
	55	75	6SE6440-2UE35-5FA1					3NA3136-6	3NE1224-0	3VL1716-.DD33-....
	75	100	6SE6440-2UE37-5FA1					3NA3136-6	3NE1224-0	3VL3720-.DC36-....
							3VL3725-.DC36-....			

Selection and ordering data (continued)

Mains voltage	Output (CT)		Inverter with internal filter Class A	Order No. of options Additional EMC filter, Class B	Line commutating choke	LC filter
	kW	hp				
1 AC 200 V to 240 V	0.12	0.16	6SE6440-2AB11-2AA1	6SE6400-2FS01-0AB0	6SE6400-3CC00-4AB3	–
	0.25	0.33	6SE6440-2AB12-5AA1			–
	0.37	0.50	6SE6440-2AB13-7AA1			6SE6400-3CC01-0AB3
	0.55	0.75	6SE6440-2AB15-5AA1			–
	0.75	1.0	6SE6440-2AB17-5AA1			–
	1.1	1.5	6SE6440-2AB21-1BA1	6SE6400-2FS02-6BB0	6SE6400-3CC02-6BB3	–
	1.5	2.0	6SE6440-2AB21-5BA1			–
	2.2	3.0	6SE6440-2AB22-2BA1			–
	3.0	4.0	6SE6440-2AB23-0CA1	6SE6400-2FS03-5CB0	6SE6400-3CC03-5CB3	–
3 AC 200 V to 240 V	3.0	4.0	6SE6440-2AC23-0CA1	6SE6400-2FS03-8CD0	6SE6400-3CC01-7CC3	–
	4.0	5.0	6SE6440-2AC24-0CA1		6SE6400-3CC03-5CD3	–
	5.5	7.5	6SE6440-2AC25-5CA1		–	–
3 AC 380 V to 480 V	2.2	3.0	6SE6440-2AD22-2BA1	6SE6400-2FS01-6BD0	6SE6400-3CC01-0BD3	6SE6400-3TD01-0BD0
	3.0	4.0	6SE6440-2AD23-0BA1			
	4.0	5.0	6SE6440-2AD24-0BA1		6SE6400-3CC01-4BD3	
	5.5	7.5	6SE6440-2AD25-5CA1	6SE6400-2FS03-8CD0	6SE6400-3CC02-2CD3	6SE6400-3TD03-2CD0
	7.5	10	6SE6440-2AD27-5CA1			
	11.0	15	6SE6440-2AD31-1CA1		6SE6400-3CC03-5CD3	
	15.0	20	6SE6440-2AD31-5DA1	An inverter without filter must be selected to satisfy the EMC requirements of Class B. In addition, an appropriate EMC filter of Class B from Schaffner is required.	6SE6400-3CC04-4DD0	6SE6400-3TD03-7DD0
	18.5	25	6SE6440-2AD31-8DA1		6SE6400-3CC05-2DD0	6SE6400-3TD04-8DD0
	22	30	6SE6440-2AD32-2DA1		6SE6400-3CC08-3ED0	6SE6400-3TD06-1DD0
	30	40	6SE6440-2AD33-0EA1		6SE6400-3CC11-2FD0	6SE6400-3TD07-2ED0
	37	50	6SE6440-2AD33-7EA1			6SE6400-3TD11-5FD0
	45	60	6SE6440-2AD34-5FA1			
	55	75	6SE6440-2AD35-5FA1			6SE6400-3TD15-0FD0
	75	100	6SE6440-2AD37-5FA1			6SE6400-3CC11-7FD0
Mains voltage	Output (CT)		Inverter with internal filter Class A	Order No. of options Output choke	Brake resistors	Gland plate
	kW	hp				
1 AC 200 V to 240 V	0.12	0.16	6SE6440-2AB11-2AA1	6SE6400-3TC00-4AD3	6SE6400-4BC05-0AA0	6SE6400-0GP00-0AA0
	0.25	0.33	6SE6440-2AB12-5AA1			
	0.37	0.50	6SE6440-2AB13-7AA1			
	0.55	0.75	6SE6440-2AB15-5AA1			
	0.75	1.0	6SE6440-2AB17-5AA1			
	1.1	1.5	6SE6440-2AB21-1BA1	6SE6400-3TC01-0BD3	6SE6400-4BC11-2BA0	6SE6400-0GP00-0BA0
	1.5	2.0	6SE6440-2AB21-5BA1			
	2.2	3.0	6SE6440-2AB22-2BA1			
	3.0	4.0	6SE6440-2AB23-0CA1	6SE6400-3TC03-2CD3	6SE6400-4BC12-5CA0	6SE6400-0GP00-0CA0
3 AC 200 V to 240 V	3.0	4.0	6SE6440-2AC23-0CA1	6SE6400-3TC03-2CD3	6SE6400-4BC12-5CA0	6SE6400-0GP00-0CA0
	4.0	5.0	6SE6440-2AC24-0CA1		6SE6400-4BC13-0CA0	
	5.5	7.5	6SE6440-2AC25-5CA1			
3 AC 380 V to 480 V	2.2	3.0	6SE6440-2AD22-2BA1	6SE6400-3TC01-0BD3	6SE6400-4BD12-0BA0	6SE6400-0GP00-0BA0
	3.0	4.0	6SE6440-2AD23-0BA1			
	4.0	5.0	6SE6440-2AD24-0BA1			
	5.5	7.5	6SE6440-2AD25-5CA1	6SE6400-3TC03-2CD3	6SE6400-4BD16-5CA0	6SE6400-0GP00-0CA0
	7.5	10	6SE6440-2AD27-5CA1			
	11.0	15	6SE6440-2AD31-1CA1			
	15.0	20	6SE6440-2AD31-5DA1	6SE6400-3TC05-4DD0	6SE6400-4BD21-2DA0	Integrated as standard for shield connection of the control cable and the power cable.
	18.5	25	6SE6440-2AD31-8DA1	6SE6400-3TC03-8DD0		
	22	30	6SE6440-2AD32-2DA1	6SE6400-3TC05-4DD0		
	30	40	6SE6440-2AD33-0EA1	6SE6400-3TC08-0ED0	6SE6400-4BD22-2EA0	
	37	50	6SE6440-2AD33-7EA1	6SE6400-3TC07-5ED0		
	45	60	6SE6440-2AD34-5FA1	6SE6400-3TC14-5FD0	6SE6400-4BD24-0FA0	
	55	75	6SE6440-2AD35-5FA1	6SE6400-3TC15-4FD0		
	75	100	6SE6440-2AD37-5FA1	6SE6400-3TC14-5FD0		

MICROMASTER 440

Options Variant dependent options

Selection and ordering data (continued)

Mains voltage	Output (CT)		Inverter with internal filter Class A	Order No. of the options Fuses (see Catalog LV 1)		Circuit-breaker (see Catalog LV 1)
	kW	hp		3NA3	3NE1 (9A)	
1 AC 200 V to 240 V	0.12	0.16	6SE6440-2AB11-2AA1	3NA3803	●	3RV1021-1EA10
	0.25	0.33	6SE6440-2AB12-5AA1			3RV1021-1HA10
	0.37	0.50	6SE6440-2AB13-7AA1			3RV1021-1JA10
	0.55	0.75	6SE6440-2AB15-5AA1	3NA3805		3RV1021-1KA10
	0.75	1.0	6SE6440-2AB17-5AA1			3RV1021-4AA10
	1.1	1.5	6SE6440-2AB21-1BA1	3NA3807		3RV1021-4DA10
	1.5	2.0	6SE6440-2AB21-5BA1			3RV1031-4EA10
	2.2	3.0	6SE6440-2AB22-2BA1	3NA3812		3RV1031-4FA10
	3.0	4.0	6SE6440-2AB23-0CA1	3NA3817		3RV1041-4JA10
3 AC 200 V to 240 V	3.0	4.0	6SE6440-2AC23-0CA1	3NA3810	●	3RV1031-4EA10
	4.0	5.0	6SE6440-2AC24-0CA1	3NA3812		3RV1031-4FA10
	5.5	7.5	6SE6440-2AC25-5CA1	3NA3814		3RV1031-4HA10
3 AC 380 V to 480 V	2.2	3.0	6SE6440-2AD22-2BA1	3NA3805	●	3RV1021-1KA10
	3.0	4.0	6SE6440-2AD23-0BA1			3RV1021-4AA10
	4.0	5.0	6SE6440-2AD24-0BA1	3NA3807		3RV1021-4BA10
	5.5	7.5	6SE6440-2AD25-5CA1			3RV1031-4EA10
	7.5	10	6SE6440-2AD27-5CA1	3NA3812		3RV1031-4FA10
	11.0	15	6SE6440-2AD31-1CA1	3NA3814		3RV1031-4HA10
	15.0	20	6SE6440-2AD31-5DA1	3NA3820	3NE1817-0	3RV1042-4KA10
	18.5	25	6SE6440-2AD31-8DA1	3NA3822	3NE1818-0	
	22	30	6SE6440-2AD32-2DA1	3NA3824	3NE1820-0	3RV1042-4MA10
	30	40	6SE6440-2AD33-0EA1	3NA3830	3NE1021-0	3VL1712- .DD33-
	37	50	6SE6440-2AD33-7EA1	3NA3832	3NE1022-0	3VL1716- .DD33-
	45	60	6SE6440-2AD34-5FA1	3NA3836	3NE1224-0	3VL3720- .DC36-
	55	75	6SE6440-2AD35-5FA1	3NA3140	3NE1225-0	3VL3725- .DC36-
75	100	6SE6440-2AD37-5FA1	3NA3144	3NE1227-0	3VL4731- .DC36-	

● Use in America requires
Ⓢ-listed fuses such as the
Class NON/NOS range
from Bussmann.

Overview**Basic Operator Panel (BOP)**

With the BOP, individual parameter settings can be made. Values and units are shown on a 5-digit display.



Basic Operator Panel (BOP)

A BOP can be used for several inverters. It can be directly mounted on the inverter or in a control cabinet door using a mounting kit.

Advanced Operator Panel (AOP)

The AOP enables MICROMASTER 440 parameter kits to be easily read and modified. In contrast to the BOP, the value and meaning of the parameters can be directly displayed as plain text in several languages by fast scrolling of the address.



Advanced Operator Panel (AOP)

The AOP is directly plugged into the inverter, or communicates with the latter through a door mounting kit. Together with the "AOP door mounting kit for multiple inverters", the AOP permits bus communication with up to 30 inverters at a transmission rate of 38 kbaud. (RS485, USS).

For servicing purposes, the AOP furthermore supports the download and upload of complete parameter kits.

Asian Advanced Operator Panel (AAOP)

The AAOP is the Chinese version of the AOP operator panel. It has an enhanced display and supports the operating languages of Chinese (simplified) and English.



Asian Advanced Operator Panel (AAOP)

Cyrillic Advanced Operator Panel (CAOP)

The CAOP is the Cyrillic version of the AOP Advanced Operator Panel. It supports the Cyrillic, German and English operator languages.

PROFIBUS module

For a complete PROFIBUS connection with up to ≤ 12 Mbaud. Remote control of the inverter is possible with the PROFIBUS module. Remote control and operation at the inverter can be combined using an operator panel plugged onto the PROFIBUS module. The PROFIBUS module can be supplied by an external 24 V DC power supply and is thus also active when the inverter is disconnected from the power supply.

Connection by means of a 9-pin Sub-D connector (available as an option).

DeviceNet module

For networking the inverters to the DeviceNet fieldbus system widely used on the American market. A maximum transmission rate of 500 kbaud is possible. Remote control of the inverter is possible with the DeviceNet module. Remote control and operation at the inverter can be combined using an operator panel plugged onto the DeviceNet module.

The connection to the DeviceNet bus system is made using a 5-pin connector with terminal strip.

CANopen module

Using the CANopen communications module, an inverter can be linked to the CANopen fieldbus system and remote control is then possible.

Remote control and operation at the inverter can be combined using an operator panel plugged onto the CANopen module.

The module is connected to the bus system through a 9-pin Sub-D connector.

Pulse encoder evaluation module

The pulse encoder evaluation module permits direct connection of the most widely encountered digital pulse encoders to the inverter.

They offer the following functions:

- Zero speed at full load torque
- Extremely accurate speed control
- Increased dynamic response of speed and torque control.

This module can be used with HTL and TTL pulse encoders (High voltage Transistor Logic, 24 V and Transistor Logic, 5 V).

MICROMASTER 440

Options

Variant independent options

Overview (continued)

Connection kit for PC to inverter

For controlling an inverter directly from a PC if the appropriate software has been installed (e.g. STARTER). Isolated RS-232 adapter module for reliable point-to-point connection to a PC. Includes a Sub-D connector and an RS-232 standard cable (3 m).

Connection kit for PC to AOP

For connecting a PC to an AOP or AAOP. Offline programming of inverters and archiving of parameter kits possible. Includes a desktop attachment kit for an AOP or AAOP, an RS-232 standard cable (3 m) with Sub-D connectors and a universal power supply unit.

Operator panel door mounting kit for single inverter

For mounting an operator panel in a control cabinet door. Degree of protection IP56. Contains a cable adapter module with screwless terminals for use with user's own RS-232 cables¹⁾.

AOP door mounting kit for multiple inverters (USS)

For mounting an AOP or AAOP in a control cabinet door. Degree of protection IP56. The AOP or AAOP can communicate with several inverters by means of the RS-485 USS protocol. The 4-pin connecting cable from the AOP or AAOP to the RS-485 terminals of the inverter and to the 24 V user terminal strip is not included²⁾.

Start-up tools

- **STARTER**
Starter is graphic start-up software for guided start-up for MICROMASTER 410/420/430/440 frequency inverters under Windows 2000/XP Professional. Parameter lists can be read out, altered, stored, entered and printed.
- **DriveMonitor**
is a start-up software for list-oriented programming of frequency inverters. This program executes under Windows 98/NT/2000/ME/XP Professional.

Both programs are included on the Docu DVD which is provided with every inverter.

Selection and ordering data

The options listed here are suitable for all MICROMASTER 440 inverters.

Options	Order No.	
Basic Operator Panel (BOP)	6SE6400-0BP00-0AA0	
Advanced Operator Panel (AOP)	6SE6400-0AP00-0AA1	
Asian Advanced Operator Panel (AAOP)	6SE6400-0AP00-0AB0	
Cyrillic Advanced Operator Panel (CAOP)	6SE6400-0AP00-0CA0	
PROFIBUS module	6SE6400-1PB00-0AA0	
DeviceNet module	6SE6400-1DN00-0AA0	
CANopen module	6SE6400-1CB00-0AA0	
Pulse encoder evaluation module	6SE6400-0EN00-0AA0	
RS485/PROFIBUS bus connector	6GK1500-0FC00	
Connection kit for PC to inverter	6SE6400-1PC00-0AA0	
Connection kit for PC to AOP	6SE6400-0PA00-0AA0	
Operator panel door mounting kit for single inverter	6SE6400-0PM00-0AA0	
AOP door mounting kit for multiple inverters (USS)	6SE6400-0MD00-0AA0	
Start-up tool STARTER on DVD	6SL3072-0AA00-0AG0	Available on the Internet at: http://support.automation.siemens.com/WW/view/en/10804985/133100

1) A shielded cable of type Belden 8132 (28 AWG) is recommended. The maximum cable length is 5 m for RS-232.

2) A shielded cable of type Belden 8132 (28 AWG) is recommended. The maximum cable length is 10 m for RS-485.



Technical data

		PROFIBUS module 6SE6400-1PB00-0AA0	DeviceNet module 6SE6400-1DN00-0AA0
			
Size (height x width x depth)		161 mm x 73 mm x 46 mm	
Degree of protection		IP20	
Degree of pollution		2 to IEC 60664-1 (DIN VDE 0110/T1), no condensation permitted during operation	
Strain resistance		to IEC 60068-2-6 (if module is installed correctly)	
• Stationary	Deflection	0.15 mm in the frequency range of 10 Hz to 58 Hz	
	Acceleration	19.6 m/s ² in the frequency range of 58 Hz to 500 Hz	
• Transport	Deflection	3.5 mm in the frequency range of 5 Hz to 9 Hz	
	Acceleration	9.8 m/s ² in the frequency range of 9 Hz to 500 Hz	
Climatic category (during operation)		3K3 to IEC 60721-3-3	
Cooling method		Natural air cooling	
Permissible ambient or cooling agent temperature			
• Operation		-10 °C to +50 °C (+14 °F to +122 °F)	
• Storage and transport		-25 °C to +70 °C (-13 °F to +158 °F)	
Relative humidity (permissible humidity rating)			
• Operation		≤ 85 % (non-condensing)	
• Storage and transport		≤ 95 %	
Electromagnetic compatibility		Emission	to EN 55011 (1991) Class A
		Interference	to IEC 60801-3 and EN 61000-4-3
Power supply		6.5 V ± 5 %, max. 300 mA, internal from inverter or 24 V ± 10 %, max. 350 mA, external	6.5 V ± 5 %, max. 300 mA internal from inverter or 24 V, max. 60 mA from DeviceNet-Bus
Output voltage		5 V ± 10 %, max. 100 mA, galvanically isolated supply <ul style="list-style-type: none"> • for terminating the serial interface bus or • for supplying the OLP (Optical Link Plug) 	–
Data transmission rate		max. 12 Mbaud	125, 250 and 500 Kbaud

MICROMASTER 440

Options Variant independent options

Technical data (continued)

		CANopen module 6SE6400-1CB00-0AA0	Pulse encoder evaluation module 6SE6400-0EN00-0AA0
			
Size (height x width x depth)		161 mm x 73 mm x 46 mm	161 mm x 73 mm x 42 mm
Degree of protection		IP20	
Degree of pollution		2 to IEC 60 664-1 (DIN VDE 0110/T1), no condensation permitted during operation	
Strain resistance		to IEC 60 068-2-6 (if module is installed correctly)	
• Stationary	Deflection	0.15 mm in the frequency range of 10 Hz to 58 Hz	
	Acceleration	19.6 m/s ² in the frequency range of 58 Hz to 500 Hz	
• Transport	Deflection	3.5 mm in the frequency range of 5 Hz to 9 Hz	
	Acceleration	9.8 m/s ² in the frequency range of 9 Hz to 500 Hz	
Climatic category (during operation)		3K3 to IEC 60 721-3-3	
Cooling method		Natural air cooling	
Permissible ambient or cooling agent temperature			
• Operation		-10 °C to +50 °C (+14 °F to +122 °F)	-10 °C to +50 °C (+14 °F to +122 °F)
• Storage		-40 °C to +70 °C (-40 °F to +158 °F)	-20 °C to +70 °C (-14 °F to +158 °F)
• Transportation		-25 °C to +70 °C (-13 °F to +158 °F)	-20 °C to +70 °C (-14 °F to +158 °F)
Electromagnetic compatibility		to EN 55 011 (1991) Class A	
	Emission	to IEC 60 801-3 and EN 61 000-4-3	
Relative humidity (permissible humidity rating)			
• Operation		≤ 85 % (non-condensing)	
• Storage and transport		≤ 95 %	
Power supply		The CAN bus is supplied from the inverter power supply	5 V ± 5 %, 330 mA or 18 V non-regulated, 140 mA, short-circuit proof
Data transmission rate		10, 20, 50, 125, 250, 500, 800 kbaud and 1 Mbaud	-
Pulse frequency		-	max. 300 kHz

Selection and ordering data

Type of documentation	Language	Order No.
Docu pack , supplied with each inverter, containing DVD ¹⁾ and Getting Started Guide ²⁾ (paper version)	Multilanguage	6SE6400-5AD00-1AP1
Operating instructions (paper version)	German, English, French, Italian, Spanish Available as pdf file on the Internet at http://support.automation.siemens.com/WW/view/en/10804926/133300	
Parameter list (paper version)	German, English, French, Italian, Spanish Available as pdf file on the Internet at http://support.automation.siemens.com/WW/view/en/10804926/133300	

1) The DVD contains operating instructions, parameter list, commissioning tools STARTER and DriveMonitor, multilanguage.

Available on the Internet: DriveMonitor at <http://support.automation.siemens.com/WW/view/en/10804984/133100>

STARTER at <http://support.automation.siemens.com/WW/view/en/10804985/133100>

2) Available on the Internet at <http://support.automation.siemens.com/WW/view/en/10804926/133300>

MICROMASTER 440

Dimension drawings

MICROMASTER 440 inverter

Frame size	1/3 AC 200 V to 240 V	3 AC 380 V to 480 V	3 AC 500 V to 600 V
A	0.12 kW to 0.75 kW	0.37 kW to 1.5 kW	–
B	1.1 kW to 2.2 kW	2.2 kW to 4 kW	–
C	3 kW to 5.5 kW	5.5 kW to 11 kW	0.75 kW to 11 kW

The specified outputs are valid for CT mode.

Note:
The inverters must not be mounted horizontally. But the inverters can be mounted without lateral spacing.

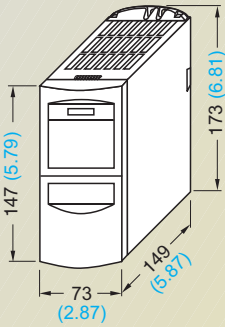

Inverter frame size **A**

Drill and fixing pattern

Fixing with 2 x M4 bolts, 2 x M4 nuts, 2 x M4 washers or by snapping onto a rail
Tightening torque with washers fitted: 2.5 Nm
Ventilation clearance required
Top and bottom: 100 mm

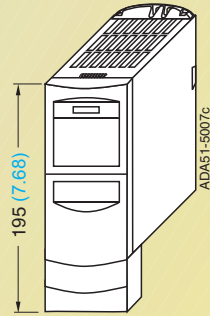

Inverter frame size **A** with **gland plate**

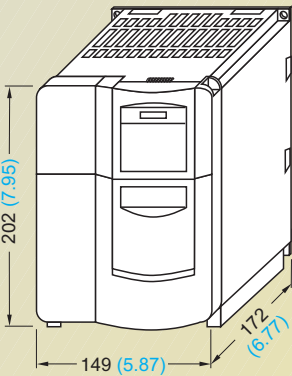

Inverter frame size **B**

Drill pattern

Fixing with 4 x M4 bolts, 4 x M4 nuts, 4 x M4 washers
Tightening torque with washers fitted: 2.5 Nm
Ventilation clearance required
Top and bottom: 100 mm

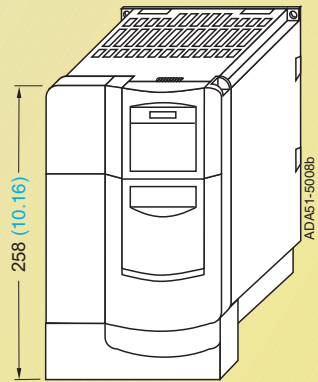

Inverter frame size **B** with **gland plate**

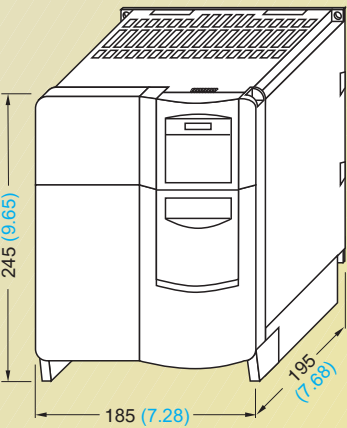

Inverter frame size **C**

Drill pattern

Fixing with 4 x M5 bolts, 4 x M5 nuts, 4 x M5 washers
Tightening torque with washers fitted: 3.0 Nm
Ventilation clearance required
Top and bottom: 100 mm

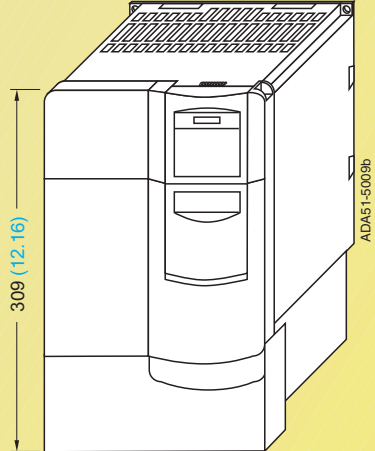

Inverter frame size **C** with **gland plate**

With the communications module, the mounting depth increases by 23 mm (0.91 inches). If a pulse encoder evaluation module is mounted in addition, the installation depth increases by another 23 mm (0.91 inches).

All dimensions in mm (values in brackets are in inches)

4

MICROMASTER 440 inverter (continued)

Frame size	3 AC 200 V to 240 V	3 AC 380 V to 480 V	3 AC 500 V to 600 V
D	7.5 kW to 15 kW	15 kW to 22 kW	15 kW to 22 kW
E	18.5 kW to 22 kW	30 kW to 37 kW	30 kW to 37 kW
F	30 kW to 45 kW	45 kW to 75 kW	45 kW to 75 kW

Note:
The inverters must not be mounted horizontally. But the inverters can be mounted without lateral spacing.

The specified outputs are valid for CT mode.

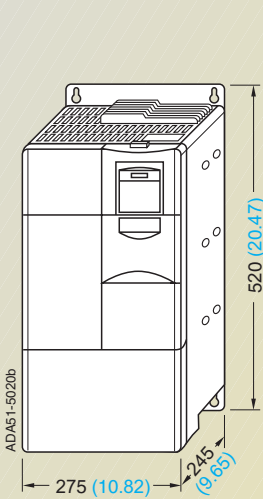

Inverter frame size D



Fixing with
4 x M8 bolts, 4 x M8 nuts,
4 x M8 washers
Tightening torque with washers
fitted: 13 Nm
Ventilation clearance required
Top and bottom: 300 mm

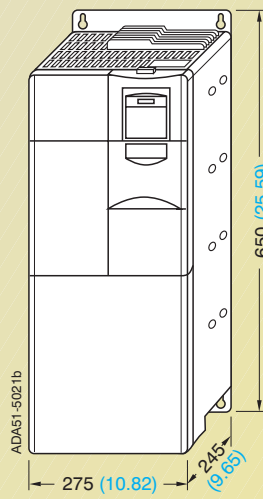

Inverter frame size E

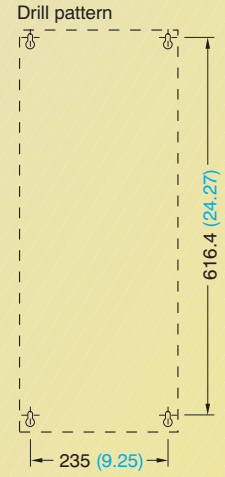

Fixing with
4 x M8 bolts, 4 x M8 nuts,
4 x M8 washers
Tightening torque with washers
fitted: 13 Nm
Ventilation clearance required
Top and bottom: 300 mm

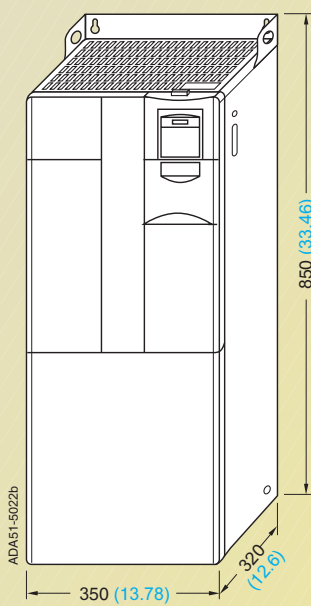

Inverter frame size F without filter



Fixing with
4 x M8 bolts, 4 x M8 nuts,
4 x M8 washers
Tightening torque with washers
fitted: 13 Nm
Ventilation clearance required
Top and bottom: 350 mm

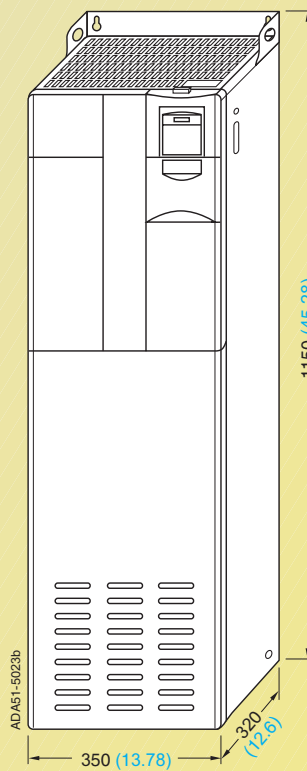

Inverter frame size F with filter

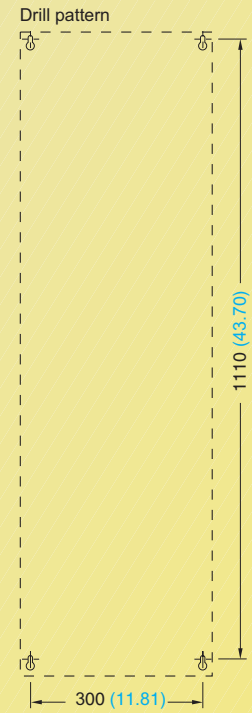

Fixing with
4 x M8 bolts, 4 x M8 nuts,
4 x M8 washers
Tightening torque with washers
fitted: 13 Nm
Ventilation clearance required
Top and bottom: 350 mm

All dimensions in mm (values in brackets are in inches)

MICROMASTER 440

Dimension drawings

MICROMASTER 440 inverter (continued)

Frame size	3 AC 380 V to 480 V
FX	90 kW to 110 kW
GX	132 kW to 200 kW

Note:
The inverters must not be mounted horizontally. But the inverters can be mounted without lateral spacing.

The specified outputs are valid for CT mode.

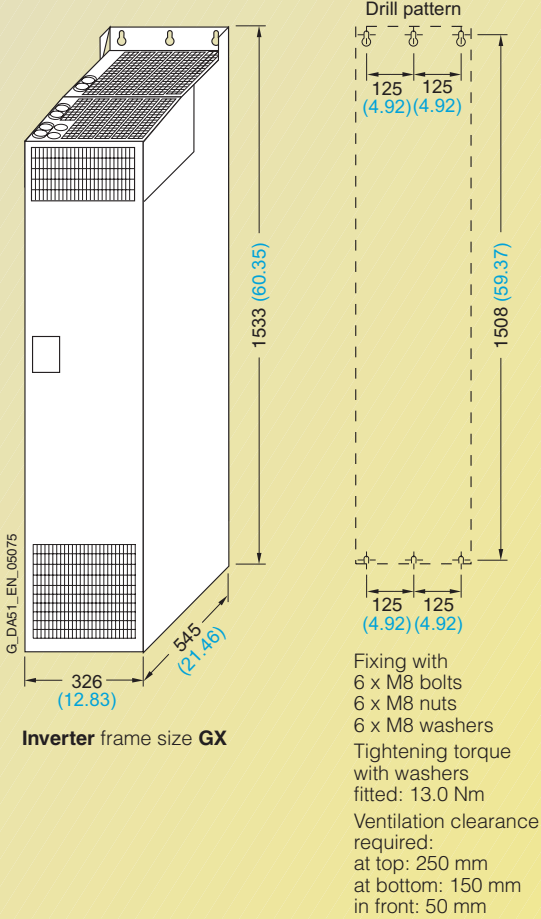
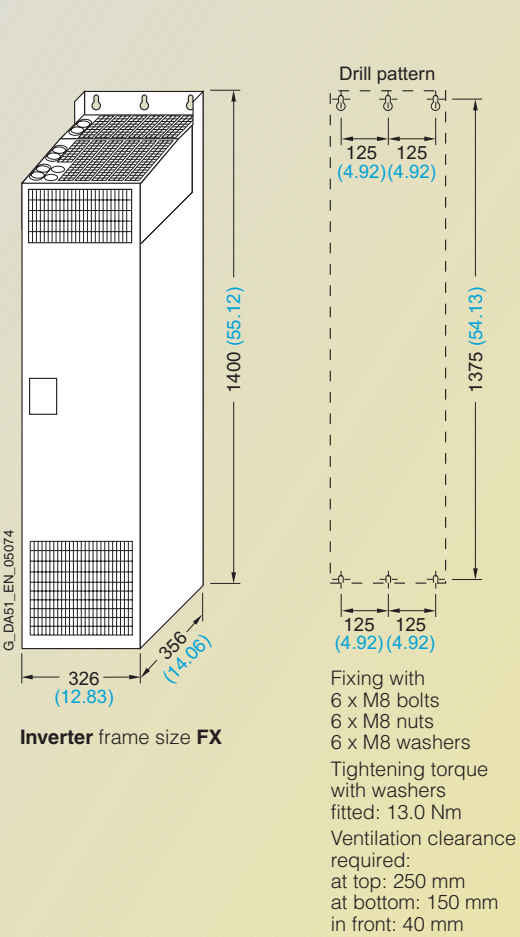

All dimensions in mm (values in brackets are in inches)

EMC filter

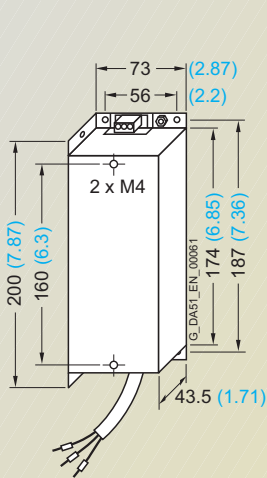

EMC filter for frame size **A**

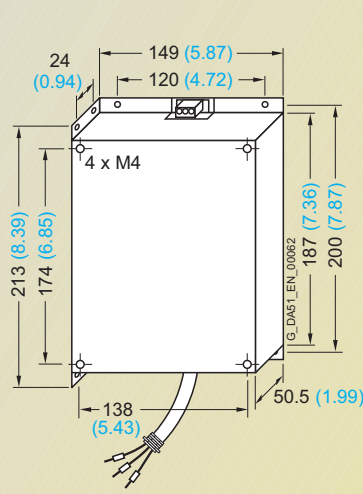

For frame size **B**

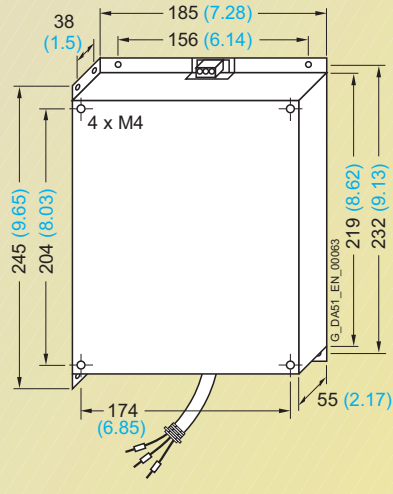

For frame size **C**

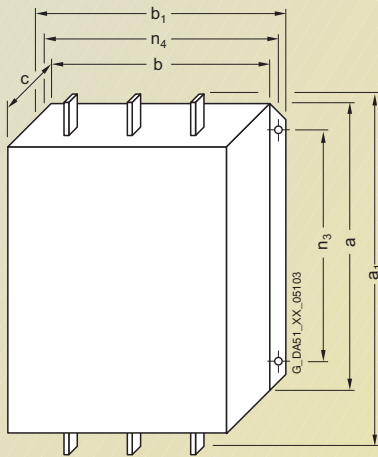

EMC filter Class A Type 6SL3000-	for inverter Frame size (FS)	Dimensions							Weight, approx kg
		a	a ₁	b	b ₁	c	n ₃	n ₄	
OBE32-5AA0	FX	270 (10.63)	360 (14.17)	200 (7.87)	240 (9.45)	116 (4.57)	210 (8.27)	220 (8.66)	12.3
OBE34-4AA0	GX/GX	270 (10.63)	360 (14.17)	200 (7.87)	240 (9.45)	116 (4.57)	210 (8.27)	220 (8.66)	12.3
OBE36-0AA0	GX	310 (12.2)	400 (15.75)	215 (8.46)	265 (10.43)	140 (5.51)	250 (9.84)	240 (9.45)	19.0

EMC filter for frame sizes **FX** and **GX**

All dimensions in mm (values in brackets are in inches)

MICROMASTER 440

Dimension drawings

LC filter

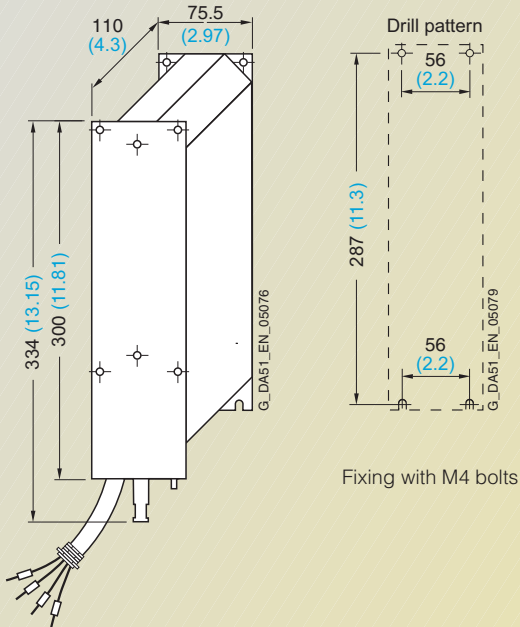

LC filter for frame size **A**

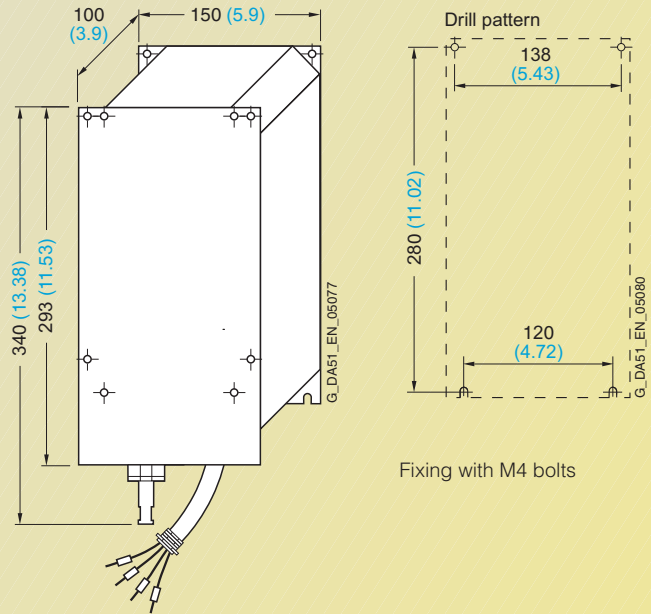

For frame size **B**

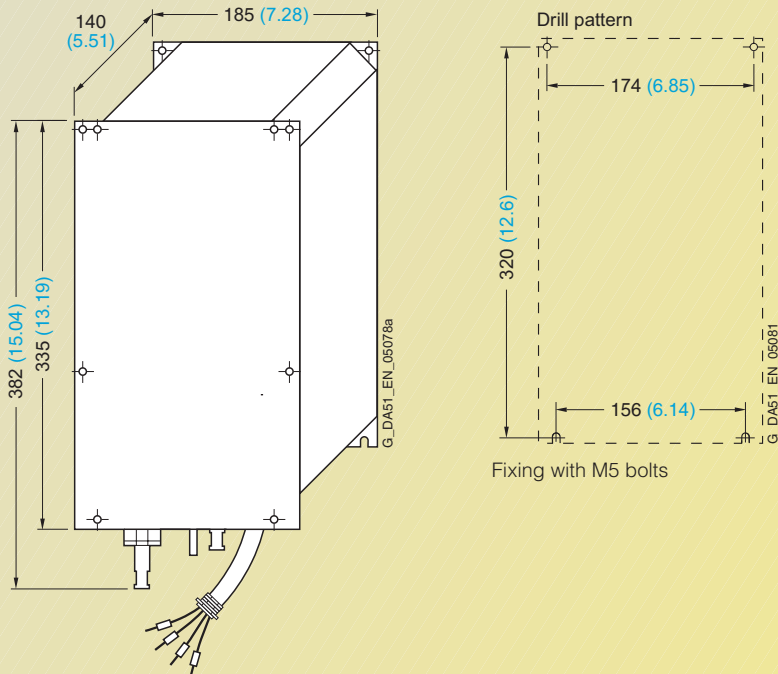

LC filter for frame size **C**

All dimensions in mm (values in brackets are in inches)

LC filter

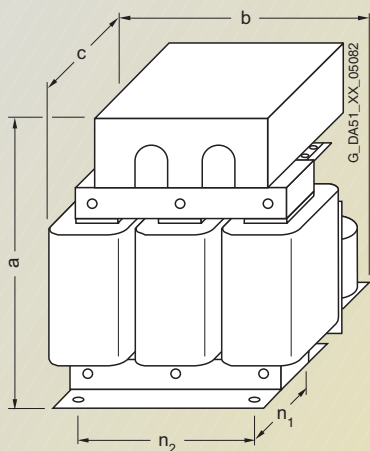

Fixing with M10 bolts

LC filter for frame sizes **D** to **F**

LC filter Type	for inverter Frame size (FS)	Dimensions					Weight, approx kg
		a	b	c	n ₁	n ₂	
6SE6400-3TD03-7DD0	D	278 (10.94)	240 (9.45)	230 (9.06)	115 (4.53)	190 (7.48)	21.0
6SE6400-3TD04-8DD0	D	290 (11.42)	240 (9.45)	240 (9.45)	125 (4.92)	190 (7.48)	26.0
6SE6400-3TD06-1DD0	D	345 (13.58)	300 (11.81)	220 (8.66)	120 (4.72)	240 (9.45)	34.0
6SE6400-3TD02-3DE0	D	280 (11.02)	240 (9.45)	240 (9.45)	125 (4.92)	190 (7.48)	26.1
6SE6400-3TD03-2DE0	D	300 (11.81)	300 (11.81)	235 (9.25)	133 (5.24)	240 (9.45)	39.5
6SE6400-3TD03-7DE0	D	310 (12.2)	300 (11.81)	250 (9.84)	145 (5.71)	240 (9.45)	42.0
6SE6400-3TD07-2ED0	E	355 (13.98)	300 (11.81)	235 (9.25)	145 (5.71)	240 (9.45)	49.5
6SE6400-3TD04-8EE0	E	345 (13.58)	300 (11.81)	260 (10.24)	160 (6.3)	240 (9.45)	48.5
6SE6400-3TD06-1EE0	E	345 (13.58)	300 (11.81)	275 (10.83)	171 (6.73)	240 (9.45)	57.5
6SE6400-3TD11-5FD0	E/F	460 (18.11)	360 (14.17)	235 (9.25)	125 (4.92)	264 (10.39)	67.0
6SE6400-3TD15-0FD0	F	460 (18.11)	360 (14.17)	250 (9.84)	140 (5.51)	264 (10.39)	75.0
6SE6400-3TD18-0FD0	F	520 (20.47)	420 (16.54)	290 (11.42)	173 (6.81)	316 (12.44)	77.5
6SE6400-3TD07-1FE0	F	380 (14.96)	300 (11.81)	285 (11.22)	171 (6.73)	240 (9.45)	70.5
6SE6400-3TD10-0FE0	F	460 (18.11)	360 (14.17)	250 (9.84)	140 (5.11)	264 (10.39)	70.5
6SE6400-3TD11-5FE0	F	515 (20.28)	420 (16.54)	290 (11.42)	173 (6.81)	316 (12.44)	125.5

All dimensions in mm (values in brackets are in inches)

MICROMASTER 440

Dimension drawings

Sinusoidal filter

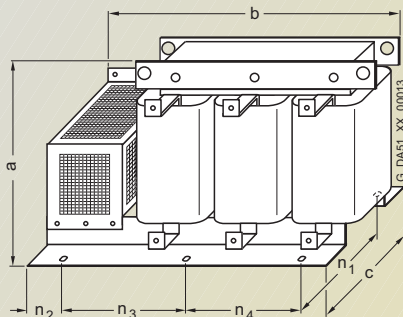

Sinusoidal filter for frame sizes **FX** and **GX**

Sinusoidal filter Type 6SL3000-	for inverter Frame size (FS)	Dimensions							Weight (max.) kg
		a	b	c	n ₁	n ₂	n ₃	n ₄	
2CE32-3AA0	FX	300 (11.81)	620 (24.41)	320 (12.6)	280 (11.02)	105 (4.13)	225 (8.86)	150 (5.91)	135.0
2CE32-8AA0	GX	300 (11.81)	620 (24.41)	320 (12.6)	280 (11.02)	105 (4.13)	225 (8.86)	150 (5.91)	138.0

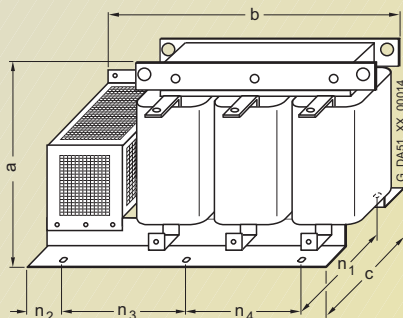

Sinusoidal filter for frame size **GX**

Sinusoidal filter Type 6SL3000-	for inverter Frame size (FS)	Dimensions							Weight (max.) kg
		a	b	c	n ₁	n ₂	n ₃	n ₄	
2CE33-3AA0	GX	370 (14.57)	620 (24.41)	360 (14.17)	320 (12.6)	105 (4.13)	225 (8.86)	150 (5.91)	144.0
2CE34-1AA0	GX	370 (14.57)	620 (24.41)	360 (14.17)	320 (12.6)	105 (4.13)	225 (8.86)	150 (5.91)	208.0

4

All dimensions in mm (values in brackets are in inches)

Line commutating chokes

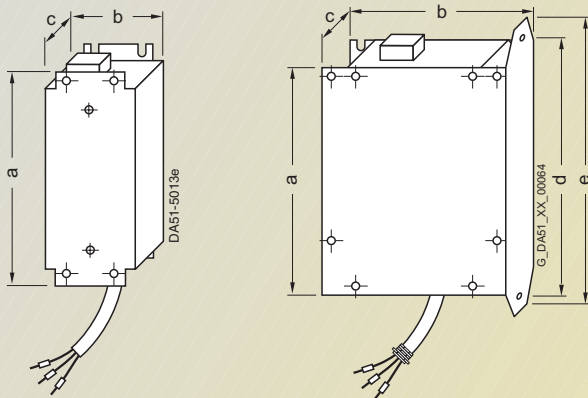

Line commutating choke for frame size **A**

For frame sizes **B** and **C**

Line commutating choke for	Dimensions					Weight (max.) kg
	a	b	c	d	e	
Frame size A	200 (7.87)	75.5 (2.97)	50 (1.97)	–	–	1.4
Frame size B	213 (8.39)	150 (5.91)	50 (1.97)	220 (8.66)	233 (9.17)	2.2
Frame size C (380–480 V)	245 (9.65)	185 (7.28)	50 (1.97)	264 (10.39)	280 (11.02)	5.1
Frame size C (500–600 V, 0.75–1.5 kW)	245 (9.65)	185 (7.28)	50 (1.97)	264 (10.39)	280 (11.02)	3.8
Frame size C (500–600 V, 2.2–4 kW)	245 (9.65)	185 (7.28)	50 (1.97)	264 (10.39)	280 (11.02)	4.0
Frame size C (500–600 V, 5.5–11 kW)	245 (9.65)	185 (7.28)	80 (3.15)	264 (10.39)	280 (11.02)	8.0

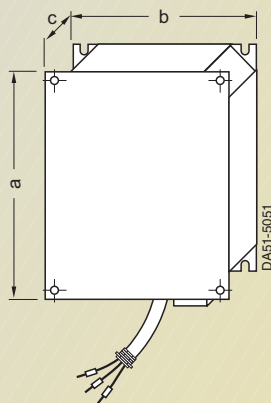

Line commutating choke for frame sizes **D** and **E**

Line commutating choke for	Dimensions			Weight (max.) kg
	a	b	c	
Frame size D	520 (20.47)	275 (10.83)	85 (3.35)	9.5
Frame size E	650 (25.59)	275 (10.83)	95 (3.74)	17.0

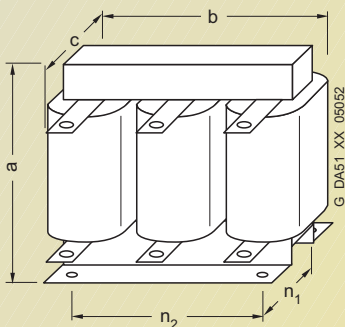

Line commutating choke for inverter frame size **F**

Line commutating choke Type	for inverter Frame size (FS)	Dimensions					Weight (max.) kg
		a	b	c	n ₁	n ₂	
6SE6400-3CC11-....	F	228 (8.98)	240 (9.45)	141 (5.55)	95 (3.74)	185 (7.28)	25.0

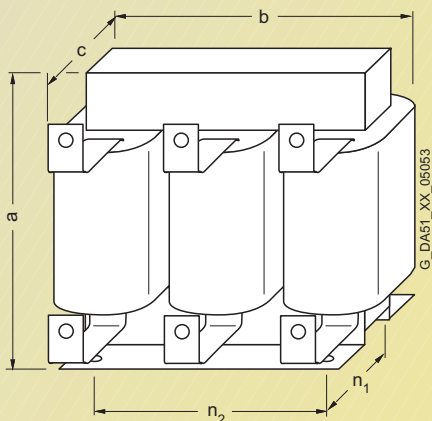

Line commutating choke for inverters of frame sizes **FX** and **GX**

Line commutating choke Type	for inverter Frame size (FS)	Dimensions					Weight (max.) kg
		a	b	c	n ₁	n ₂	
0CE32-....	FX	248 (9.76)	255 (10.04)	203 (7.99)	101 (3.98)	200 (7.87)	24.0
0CE33-....	GX	248 (9.76)	255 (10.04)	203 (7.99)	101 (3.98)	200 (7.87)	25.0
0CE35-....	GX	269 (10.59)	275 (10.83)	210 (8.27)	118 (4.65)	224 (8.82)	35.0

All dimensions in mm (values in brackets are in inches)

MICROMASTER 440

Dimension drawings

Output chokes

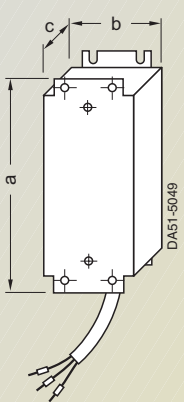

Output choke
for frame size **A**
6SE6400-3TC00-4AD2
6SE6400-3TC00-4AD3

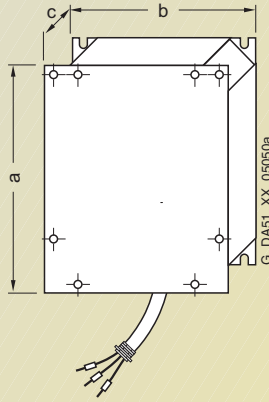

For frame sizes **B** and **C**
6SE6400-3TC01-0BD3
6SE6400-3TC01-8CE3
6SE6400-3TC03-2CD3

Output choke Type 6SE6400-	Dimensions			Weight (max.) kg
	a	b	c	
3TC00-4AD2	200 (7.87)	75.5 (2.97)	110 (4.33)	1.9
3TC00-4AD3	200 (7.87)	75.5 (2.97)	50 (1.97)	1.3
3TC01-0BD3	213 (8.39)	150 (5.91)	80 (3.15)	4.1
3TC01-8CE3	245 (9.65)	185 (7.28)	110 (4.33)	10.8
3TC03-2CD3	245 (9.65)	185 (7.28)	80 (3.15)	6.6

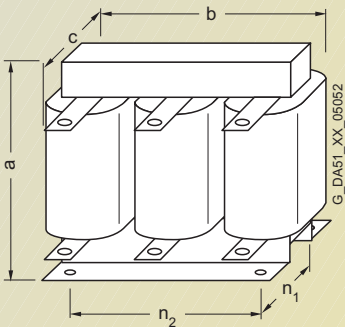

Output chokes
for inverters of frame sizes **D, E** and **F**

Output choke Type 6SE6400-	for inverter Frame size (FS)	Dimensions			to DIN 41 308		Weight (max.) kg
		a	b	c	n ₁	n ₂	
3TC03-2DE0	D	210 (8.27)	225 (8.86)	179 (7.05)	94 (3.70)	176 (6.93)	16.0
3TC03-8DD0	D	210 (8.27)	225 (8.86)	179 (7.05)	94 (3.70)	176 (6.93)	16.1
3TC05-4DD0	D	210 (8.27)	225 (8.86)	150 (5.91)	70 (2.76)	176 (6.93)	10.7
3TC06-2FE0	F	269 (10.59)	300 (11.81)	220 (8.66)	118 (4.65)	224 (8.82)	33.9
3TC07-5ED0	E	248 (9.76)	270 (10.63)	209 (8.23)	101 (3.98)	200 (7.87)	24.9
3TC08-0ED0	E	210 (8.27)	225 (8.86)	150 (5.91)	70 (2.76)	176 (6.93)	10.4
3TC08-8FE0	F	321 (12.64)	350 (13.78)	288 (11.34)	138 (5.43)	264 (10.39)	51.5
3TC14-5FD0	F	321 (12.64)	350 (13.78)	288 (11.34)	138 (5.43)	264 (10.39)	51.5
3TC15-4FD0	F	248 (9.76)	270 (10.63)	209 (8.23)	101 (3.98)	200 (7.87)	24.0

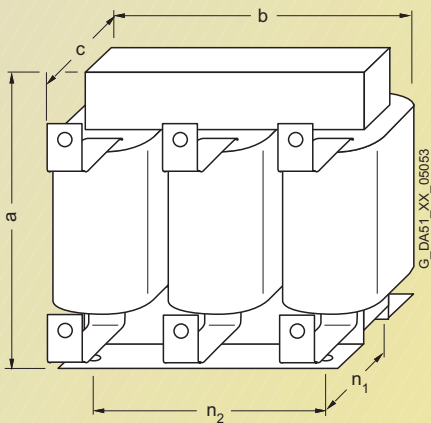

Output chokes
for inverters of frame sizes **FX** and **GX**

Output choke Type 6SL3000-	for inverter Frame size (FS)	Dimensions					Weight (max.) kg
		a	b	c	n ₁	n ₂	
2BE32-1AA0	FX	285 (11.22)	300 (11.81)	257 (10.12)	163 (6.42)	224 (8.82)	60.0
2BE32-6AA0	FX	315 (12.4)	300 (11.81)	277 (10.91)	183 (7.2)	224 (8.82)	66.0
2BE33-2AA0	GX	285 (11.22)	300 (11.81)	257 (10.12)	163 (6.42)	224 (8.82)	62.0
2BE33-8AA0	GX	285 (11.22)	300 (11.81)	277 (10.91)	183 (7.2)	224 (8.82)	73.0
2BE35-0AA0	GX	365 (14.37)	300 (11.81)	277 (10.91)	183 (7.2)	224 (8.82)	100.0

All dimensions in mm (values in brackets are in inches)

4

Brake resistors

Fig. 1:

Frame sizes A, B
Frame sizes C, D, E, F

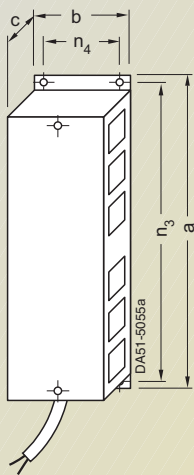

Fig. 2:

Fastening hole: circular hole Ø 5.2 mm
Fastening hole: slotted hole 6 x 12 mm
or circular hole Ø 6.5 mm

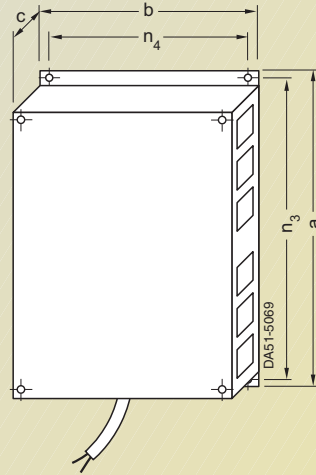
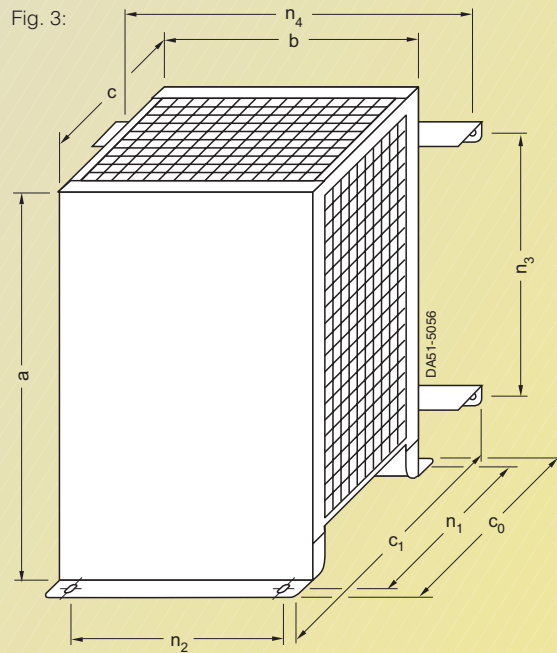

Fig. 3:



Brake resistors Type 6SE6400-	Resistor Ohm	for inverter Frame size (FS)	Figure No.	Dimensions					For floor mounting		For wall mounting		Weight (max.) kg
				a	b	c	c ₀	c ₁	n ₁	n ₂	n ₃	n ₄	
4BC05-0AA0	180	A	1	230 (9.06)	72 (2.83)	43.5 (1.71)	-	-	-	-	217 (8.54)	56 (2.20)	1.0
4BC11-2BA0	68	B	2	239 (9.41)	149 (5.87)	43.5 (1.71)	-	-	-	-	226 (8.90)	133 (5.24)	1.6
4BC12-5CA0	39	C	3	285 (11.22)	185 (7.28)	150 (5.91)	185 (7.28)	217 (8.54)	170 (6.69)	145 (5.71)	200 (7.87)	230 (9.06)	3.8
4BC13-0CA0	27	C	3	285 (11.22)	185 (7.28)	150 (5.91)	185 (7.28)	217 (8.54)	170 (6.69)	145 (5.71)	200 (7.87)	230 (9.06)	3.8
4BC18-0DA0	10	D	3	515 (20.28)	270 (10.63)	175 (6.89)	210 (8.27)	242 (9.53)	195 (7.68)	205 (8.07)	350 (13.78)	315 (12.40)	7.4
4BC21-2EA0	6.8	E	3	645 (25.39)	270 (10.63)	175 (6.89)	210 (8.27)	242 (9.53)	195 (7.68)	205 (8.07)	480 (18.90)	315 (12.40)	10.6
4BC22-5FA0	3.3	F	3	650 (25.59)	395 (15.55)	315 (12.40)	350 (13.78)	382 (15.04)	335 (13.19)	270 (10.63)	510 (20.08)	435 (17.13)	16.7
4BD11-0AA0	390	A	1	230 (9.06)	72 (2.83)	43.5 (1.71)	-	-	-	-	217 (8.54)	56 (2.20)	1.0
4BD12-0BA0	160	B	2	239 (9.41)	149 (5.87)	43.5 (1.71)	-	-	-	-	226 (8.90)	133 (5.24)	1.6
4BD16-5CA0	56	C	3	285 (11.22)	185 (7.28)	150 (5.91)	185 (7.28)	217 (8.54)	170 (6.69)	145 (5.71)	200 (7.87)	230 (9.06)	3.8
4BD21-2DA0	27	D	3	515 (20.28)	270 (10.63)	175 (6.89)	210 (8.27)	242 (9.53)	195 (7.68)	205 (8.07)	350 (13.78)	315 (12.40)	7.4
4BD22-2EA0	15	E	3	645 (25.39)	270 (10.63)	175 (6.89)	210 (8.27)	242 (9.53)	195 (7.68)	205 (8.07)	480 (18.90)	315 (12.40)	10.6
4BD24-0FA0	8.2	F	3	650 (25.59)	395 (15.55)	315 (12.40)	350 (13.78)	382 (15.04)	335 (13.19)	270 (10.63)	510 (20.08)	435 (17.13)	16.7
4BE14-5CA0	120	C	3	285 (11.22)	185 (7.28)	150 (5.91)	185 (7.28)	217 (8.54)	170 (6.69)	145 (5.71)	200 (7.87)	230 (9.06)	3.8
4BE16-5CA0	82	C	3	285 (11.22)	185 (7.28)	150 (5.91)	185 (7.28)	217 (8.54)	170 (6.69)	145 (5.71)	200 (7.87)	230 (9.06)	3.8
4BE21-3DA0	39	D	3	515 (20.28)	270 (10.63)	175 (6.89)	210 (8.27)	242 (9.53)	195 (7.68)	205 (8.07)	350 (13.78)	315 (12.40)	7.4
4BE21-8EA0	27	E	3	645 (25.39)	270 (10.63)	175 (6.89)	210 (8.27)	242 (9.53)	195 (7.68)	205 (8.07)	480 (18.90)	315 (12.40)	10.6
4BE24-2FA0	12	F	3	650 (25.59)	395 (15.55)	315 (12.40)	350 (13.78)	382 (15.04)	335 (13.19)	270 (10.63)	510 (20.08)	435 (17.13)	16.7

Brake resistors for inverters of frame sizes **A** to **F**

All dimensions in mm (values in brackets are in inches)

MICROMASTER 440

Notes

4

